

Thermoelectrics: Getting a Grip on Heat

David J. Singh
Oak Ridge National Laboratory

Co-workers:

- David Parker
- Mao-Hua Du
- Olivier Delaire
- Khuong Ong
- Jiming An
- Alaska Subedi
- Joseph Feldman

Today's Menu:

- Introduction
- Skutterudites
- PbTe / PbSe
- Mo_3Sb_7
- Oxides

Supported by DOE, BES, Materials Sciences and Engineering, the S3TEC EFRC and DOE EERE Vehicle Technologies Propulsion Materials Program.

Thermoelectric Devices

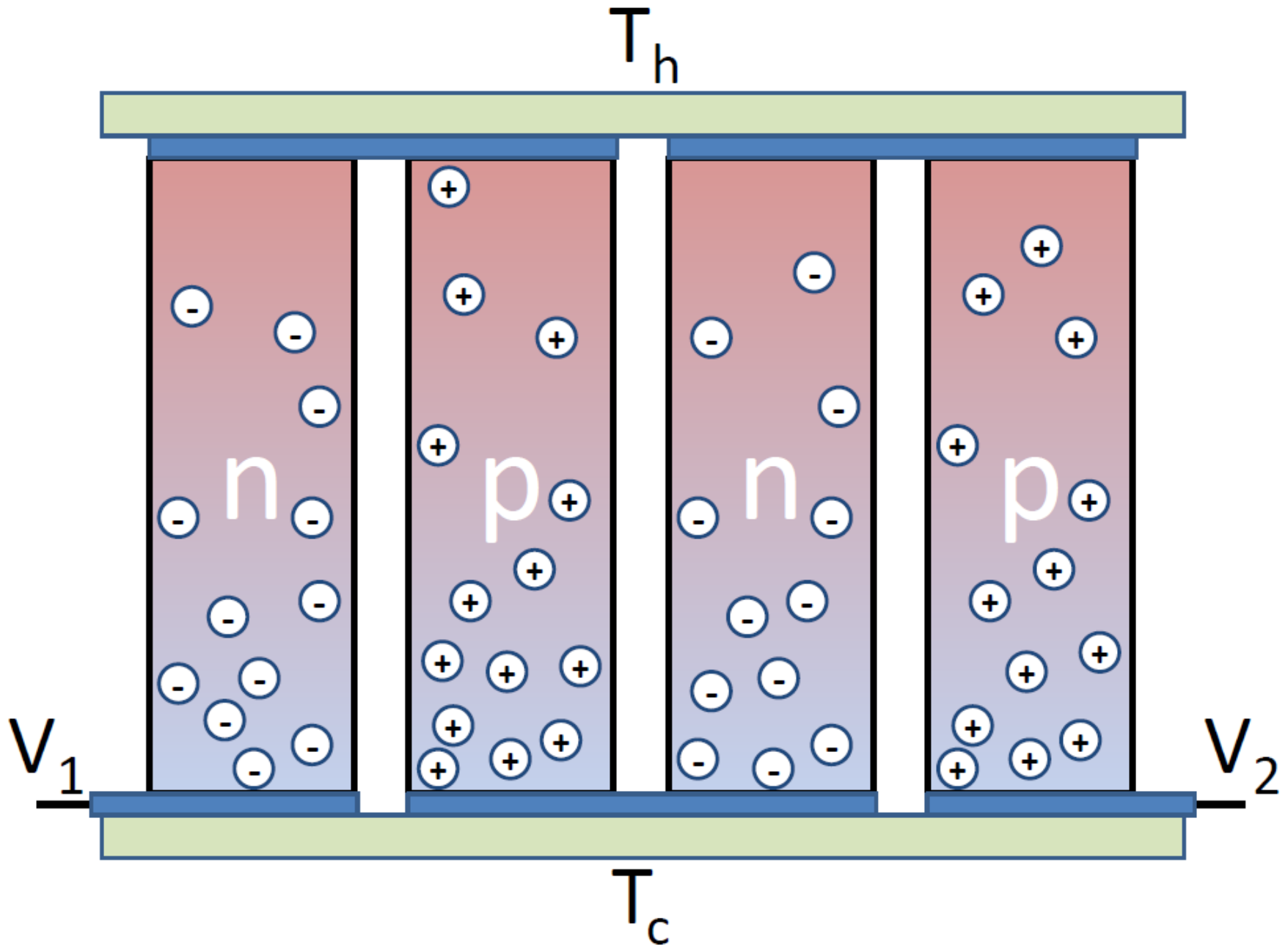

Thermoelectric Materials

Transport in a material:

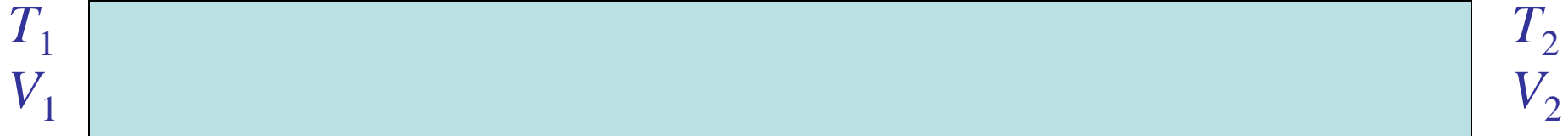

Transport:

Charge: J (electrical current density)

Heat: Q (heat current density)

Governing Equations:

$$J = \sigma [E - S \nabla T]$$

$$Q = (\sigma TS)E - \kappa \nabla T$$

S is the same due to thermodynamics.

- We want to use the cross terms, which should be large compared to the diagonal terms.

Efficiency and the Figure of Merit

For an optimal design, efficiency is limited by the TE material used.

Figure of Merit: $ZT = \frac{\sigma S^2 T}{\kappa}$ $ZT_{\max} \sim 1$ (current)

Cooling:

$$\text{COP} = \frac{T_c}{(T_h - T_c)} \frac{\gamma - T_h / T_c}{\gamma + 1} \quad \text{with } \gamma = (1 + ZT)^{1/2}$$

Generation:

$$\eta = \frac{(T_h - T_c)}{T_h} \frac{\gamma - 1}{\gamma + T_c / T_h}$$

Strong, “contra-indicated” functions of doping and T .

Applications: Durable, Solid State

Radio-isotope thermal generators (RTG) for space craft:

- Nuclear power source is required.
- Reliable operation is critical.

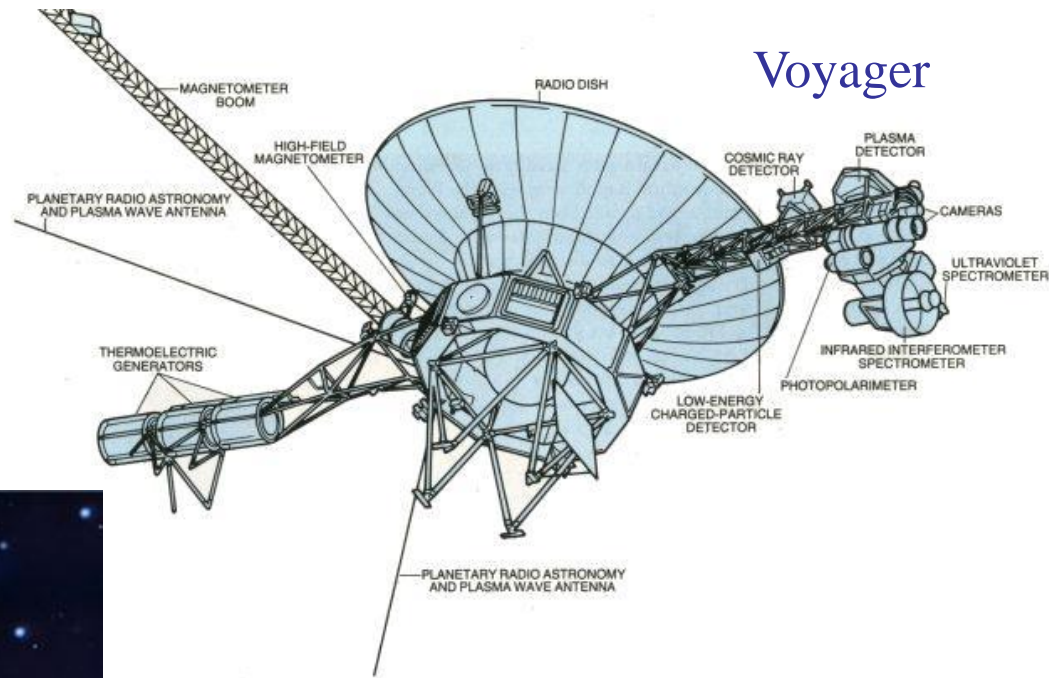

Voyager

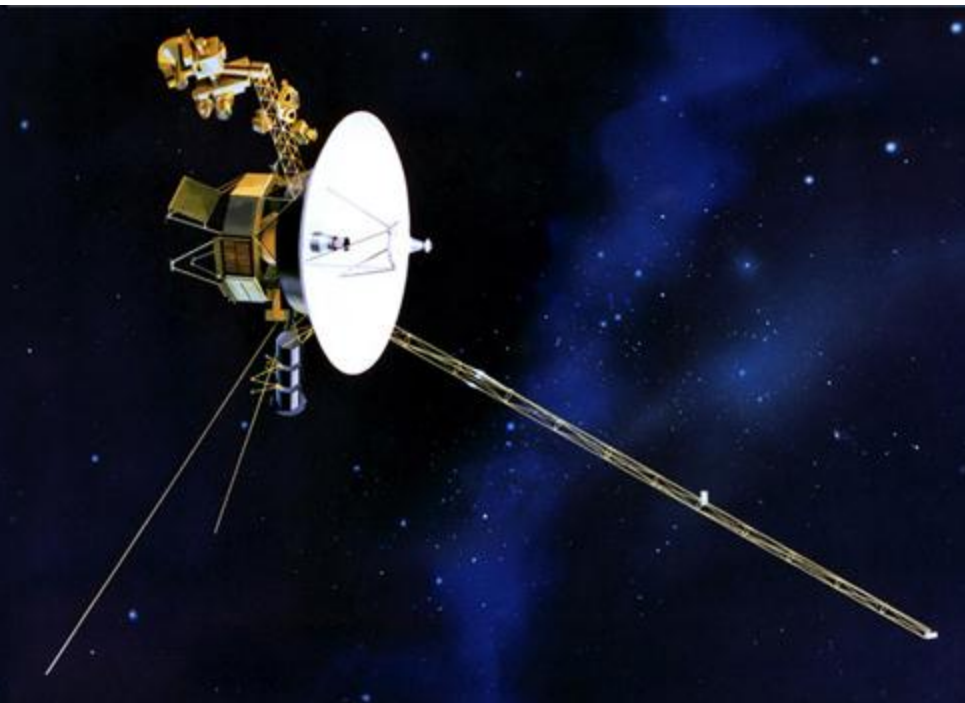

- Heat source: plutonium decay.
- Power: 100's of W.
- Lifetime: Decades.
- Servicing: None.

Applications: Vibration Free



Vibration free wine storage:

- Cost: \$100 up.
- Maintains constant T of ~ 50 F.
- Low initial cost and vibration free operation outweigh energy efficiency.

Applications: Low Cost



Mosquito Magnet

Applications: Scalable to Small Size

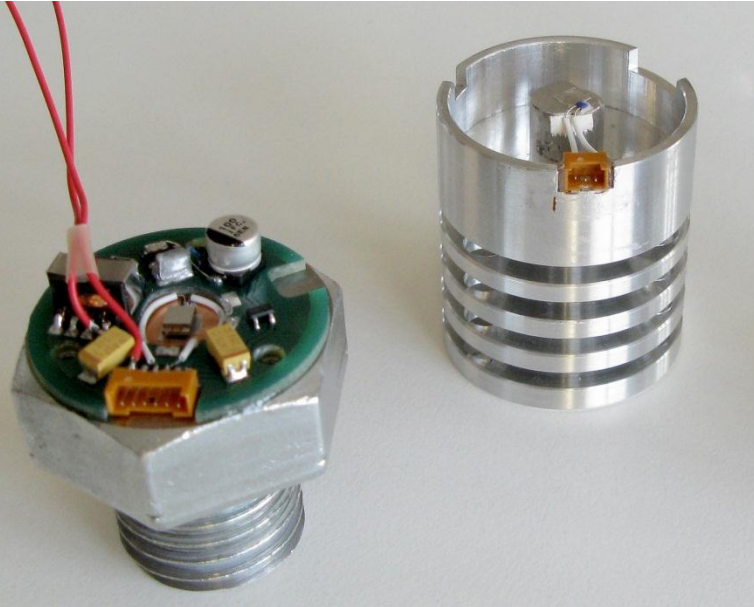

Micropelt GmbH: powerbolt
(generates ~mW from warm surfaces.)

- Eliminates need for batteries or wiring in difficult locations.

Kryotherm:
Multistage
cooler for IR
detectors.

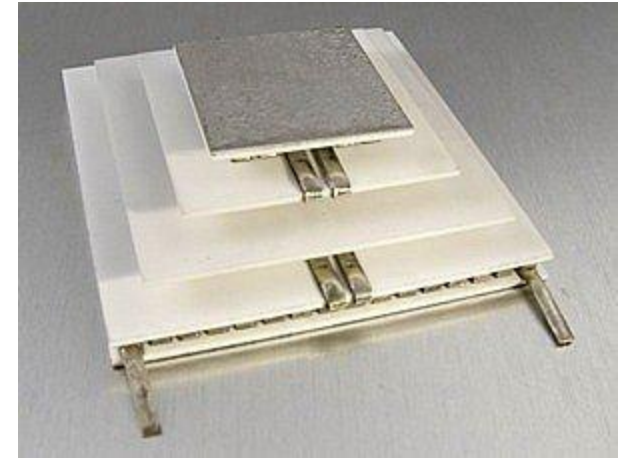

Thermoelectric CPU coolers.

Applications: Generators with Low ΔT

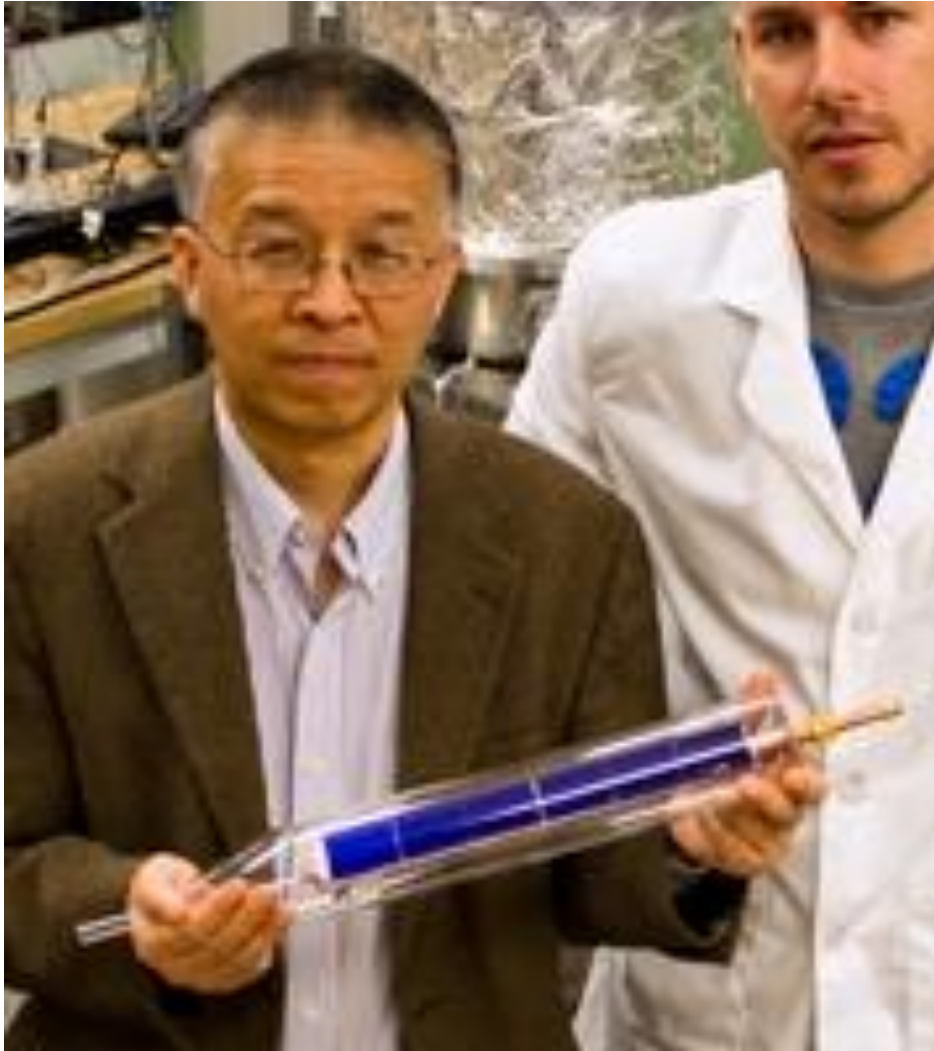

Prototype solar-thermal generator (MIT):

- Selective absorber and heat conductor in glass vacuum tube (very small amount of thermoelectric).
- $\Delta T \sim 100\text{-}200\text{ C}$.
- $> 4\%$ efficiency.
- Integrated with solar water heater.

Applications: Precise Electrical Control

Continuously variable precise heating and cooling controlled by current: (scientific instruments, analytical chemistry, medical diagnostic tests).

LDT 5900 0.005 C
temperature stability for
laser diode control (ILX
Lightwave).



Waste Heat Recovery in Vehicles

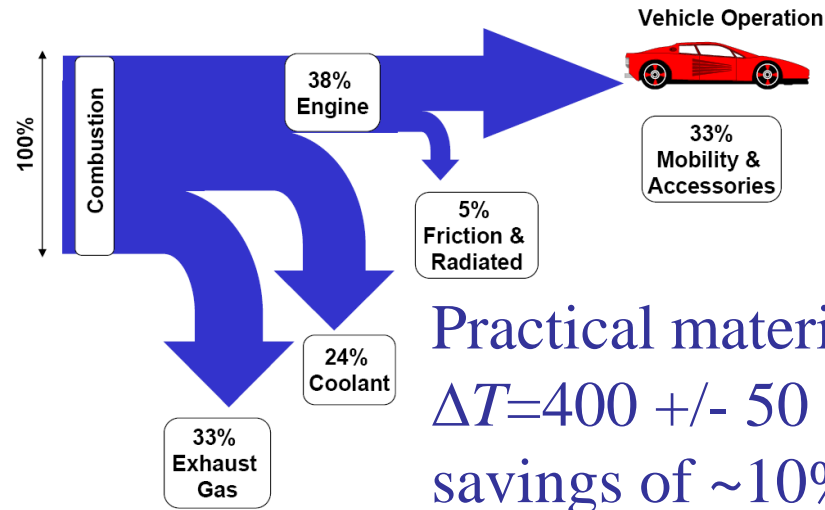

$$ZT = \sigma S^2 T / \kappa$$

Practical materials with $ZT > 2$ for $\Delta T = 400 \pm 50$ C can yield fuel savings of ~10%.

Synergy with truck electrification.

Efforts at General Motors, Ford, Toyota/Denso, BMW, Volkswagen, Bosch, Amerigon/BSST, Siemens, Cummins ...

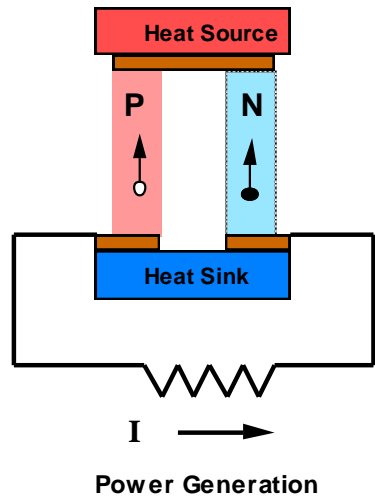

- (1) Vehicle exhaust (cars).
- (2) EGR loop (diesel trucks).

Two Application Regimes

Refrigeration: Low T

Climate controlled seat
by Amerigon
(~5M units installed)



Koolatron

Power Generation: High T

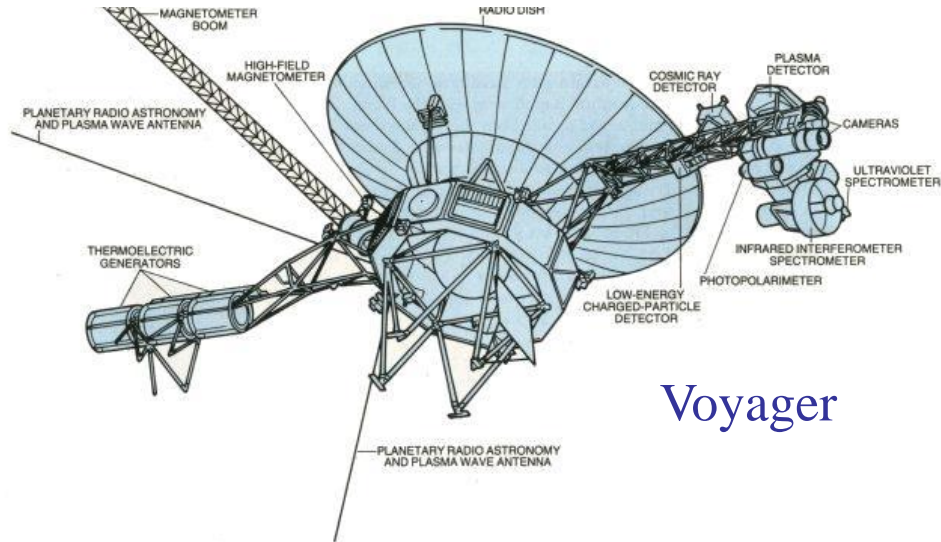
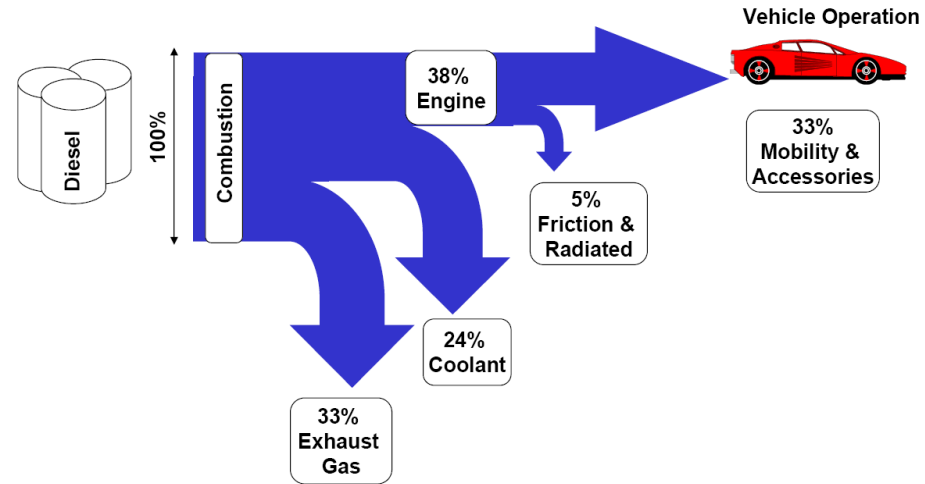

Voyager

Transport properties and mechanisms are strongly T -dependent

Electrical Transport

- Valid for mean free path longer than lattice spacing.
- Allows calculation of properties from band structure and scattering mechanisms.
- Conductivity:

$$\sigma_x(T) = e^2 \int d\varepsilon N(\varepsilon) v_x^2(\varepsilon) \tau(\varepsilon, T) (-f'(\varepsilon))$$

- Thermopower:

$$S(T) = (e/T\sigma(T)) \int d\varepsilon N(\varepsilon) v_x^2(\varepsilon) \tau(\varepsilon, T) \varepsilon (-f'(\varepsilon))$$

- At low T this is:

$$S(T) = (\pi^2 k^2 T / 3e\sigma) (d\sigma/d\varepsilon) | E_F$$

So high S implies high log derivative of σ , *i.e. strong energy dependence of electrical transport*: Band structure and scattering.

Thermopower (Band Structure View Point)

Ioffe (1957)

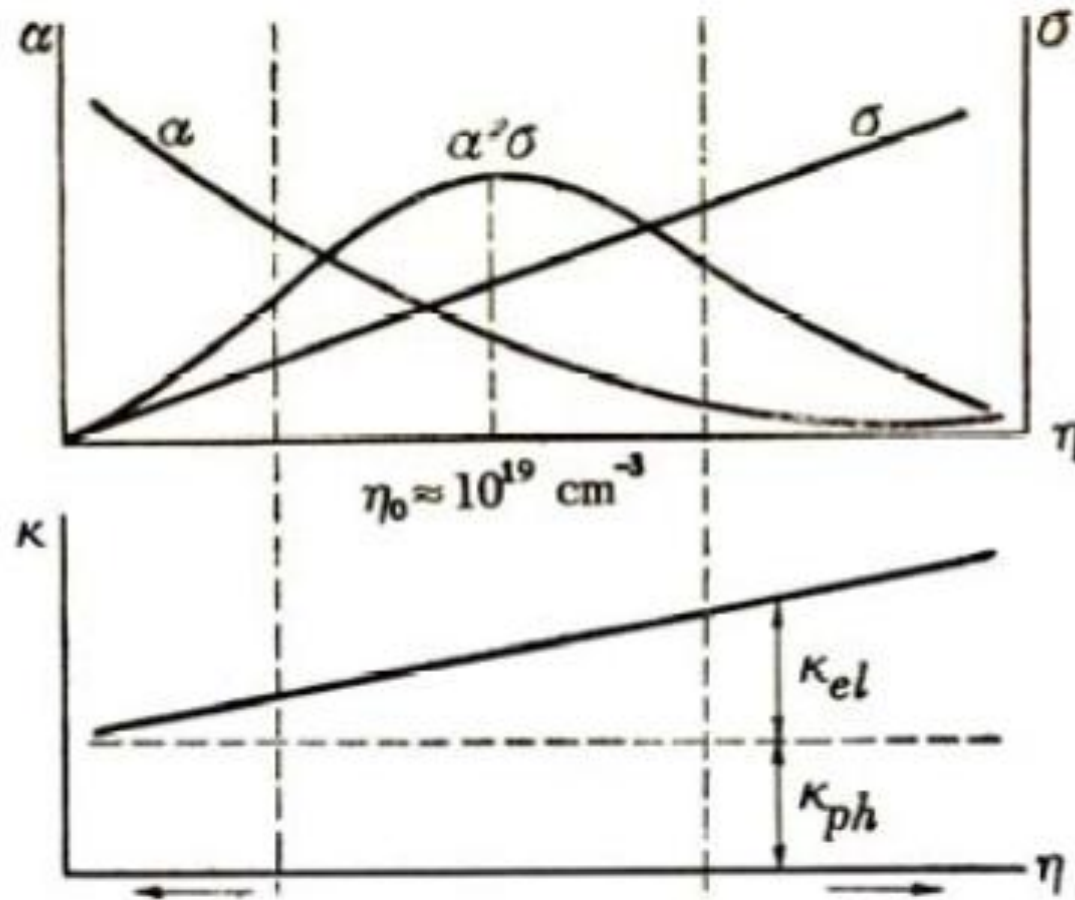

Thermopower:

- From energy dependent conductivity.

- Mott formula:

$$S = \left(\frac{\pi^2 k_B^2 T}{3e\sigma} \right) \frac{\partial \sigma}{\partial E} \Big|_{E=E_F}$$

- Note log derivative (not an extensive quantity – multiplicative factors in density of states (specific heat, entropy) or in σ do not change S).

WHAT ABOUT THERMAL CONDUCTIVITY

$ZT = \sigma S^2 T / \kappa \rightarrow$ Want low κ for high ZT .

Wiedemann-Franz Relation:

Write $\kappa = \kappa_e + \kappa_l$; WF says $\kappa_e = L\sigma T$

so get $ZT = (\kappa_e / \kappa) S^2 / L$ i.e. $ZT < S^2 / L$

$ZT = 1$ requires $S \sim 160 \mu\text{V/K}$ if lattice κ_l is negligible.

So we want:

(1) $\kappa_l \ll L\sigma T$

(2) High S

Colossal Seebeck coefficient in strongly correlated semiconductor FeSb₂

A. BENTNIEN^{1(a)}, S. JOHNSEN², G. K. H. MADSEN², B. B. IVERSEN² and F. STEGLICH¹

¹ Max Planck Institute for Chemical Physics of Solids - Nöthnitzer Straße 40, 01187 Dresden, Germany

² Department of Chemistry, University of Aarhus - Langelandsgade 140, 8000 Århus C, Denmark

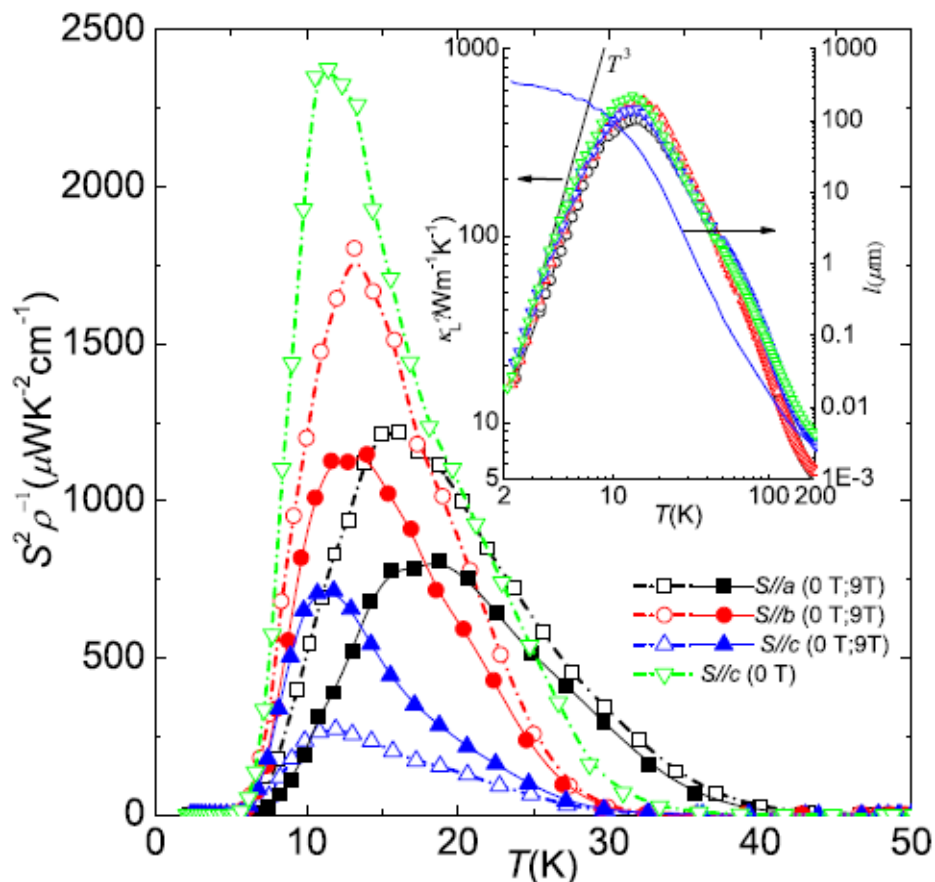
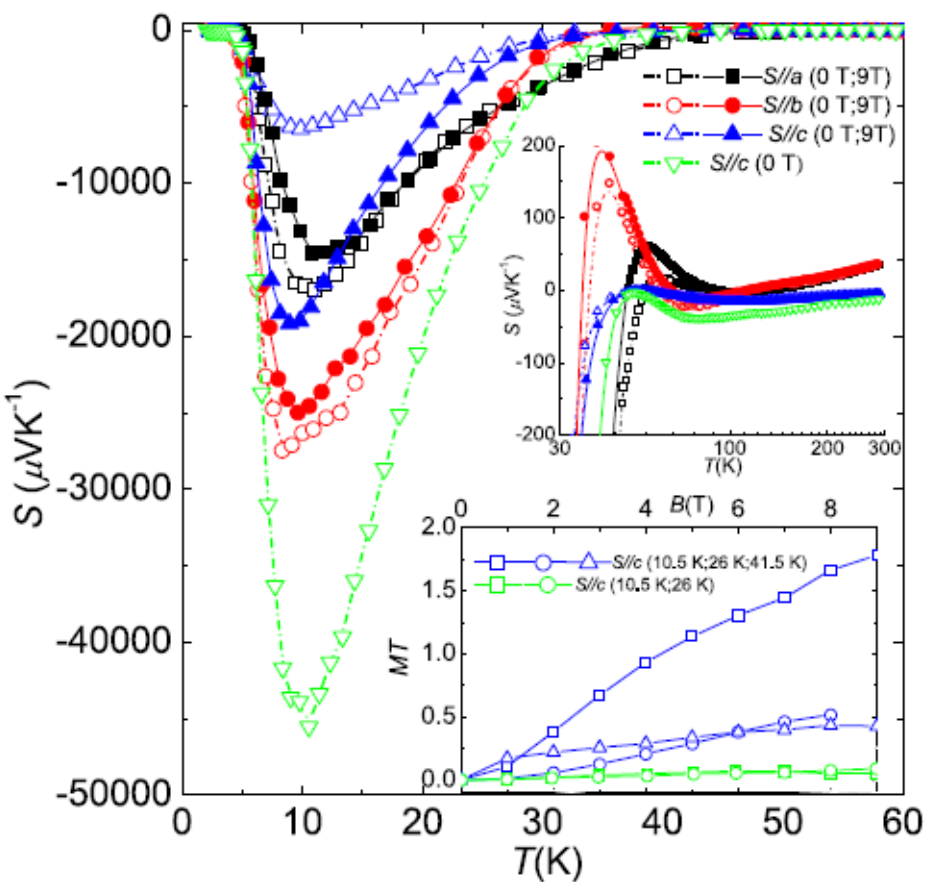

Phonon Glass Electron Crystal - PGEC (Slack)

Desire very low lattice thermal conductivity in a material with good electrical transport.

- Heavy elements and soft lattices (low sound velocities).
- Large complex unit cells.
- Structures with voids that can be filled with “rattlers”
- Disorder (alloy scattering of phonons).

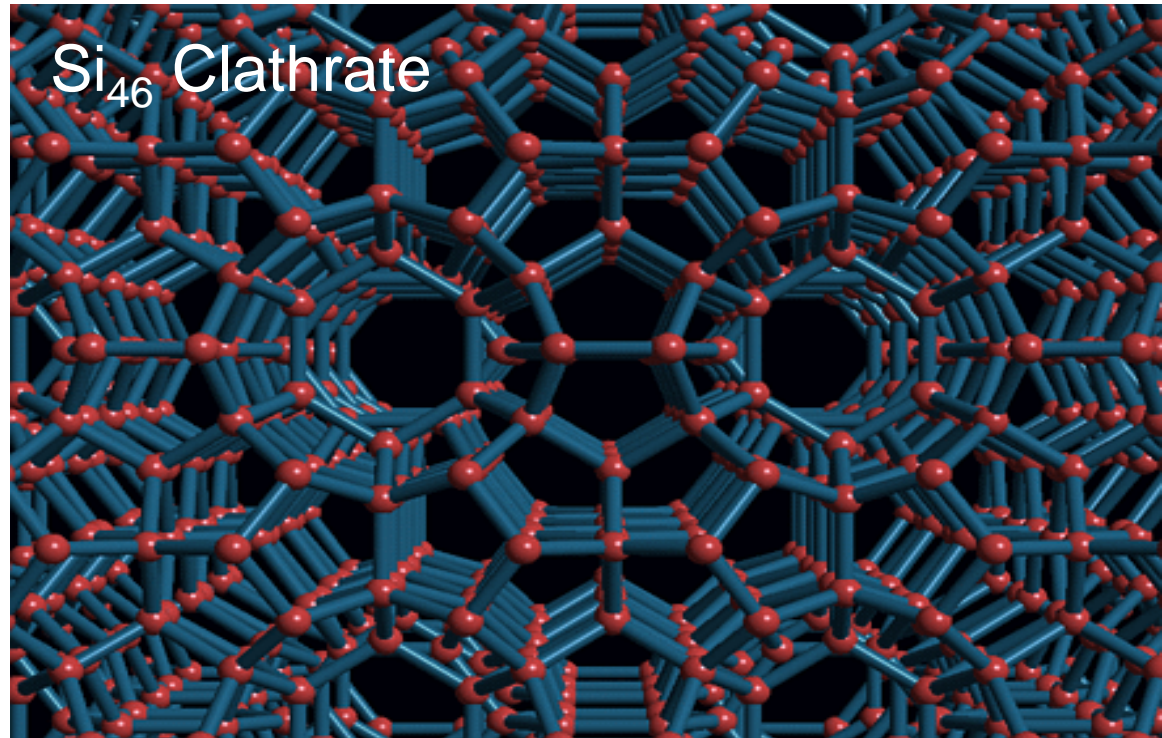

Rattling to Reduce Thermal Conductivity

Atoms in voids introduce low frequency optic modes

→ scatter acoustic heat carrying modes (Slack, Cahill)
(natural in Zintl type compounds)

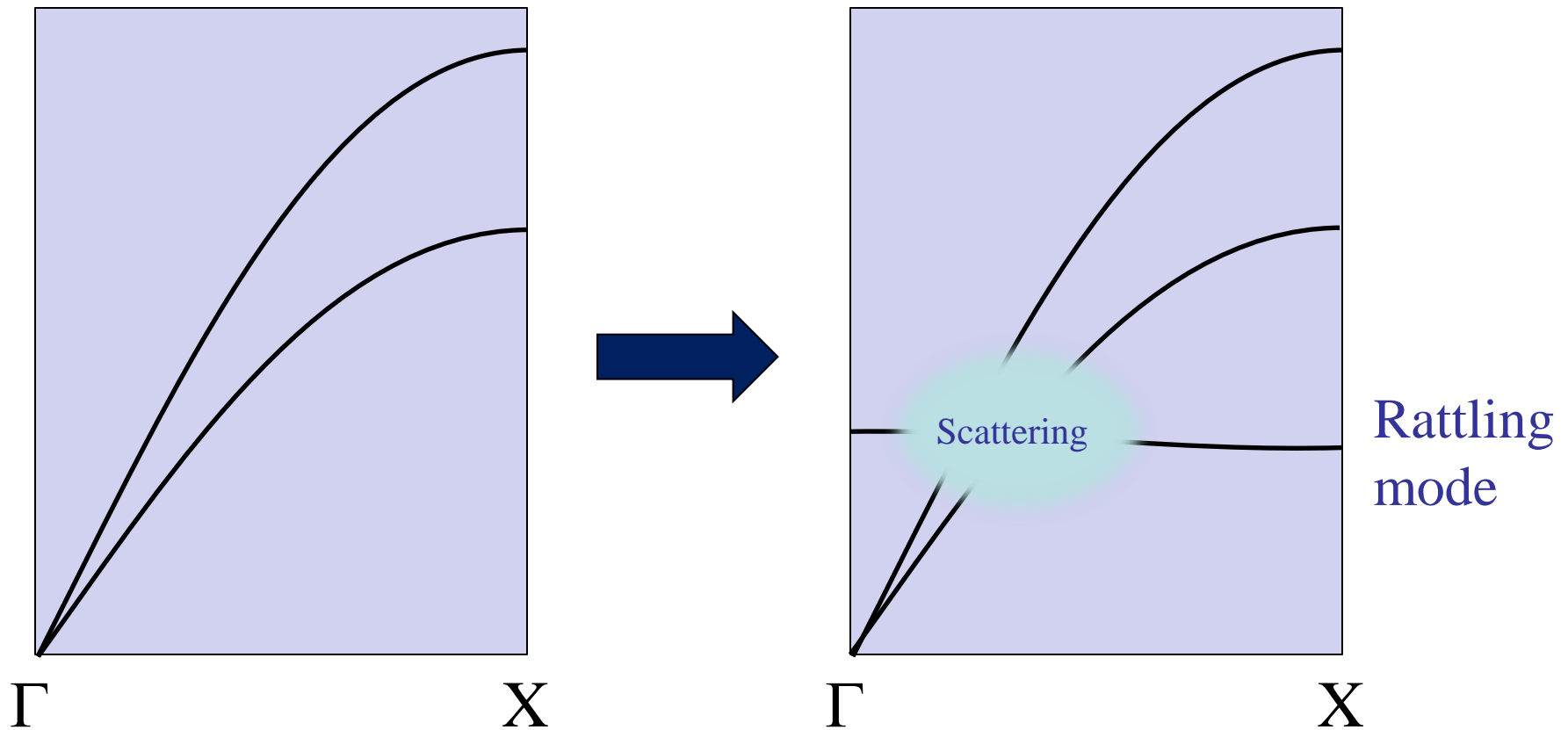

More on Lattice Heat Conduction

Electron transport: $\sigma \propto N(E_F)\langle v^2 \rangle \tau \sim N(E_F)\langle v \rangle l_e$

Heat transport: $\kappa \propto \sum G v^2 \tau \sim \sum G v l_p$

CoSb₃ (Feldman, Singh, 1996)

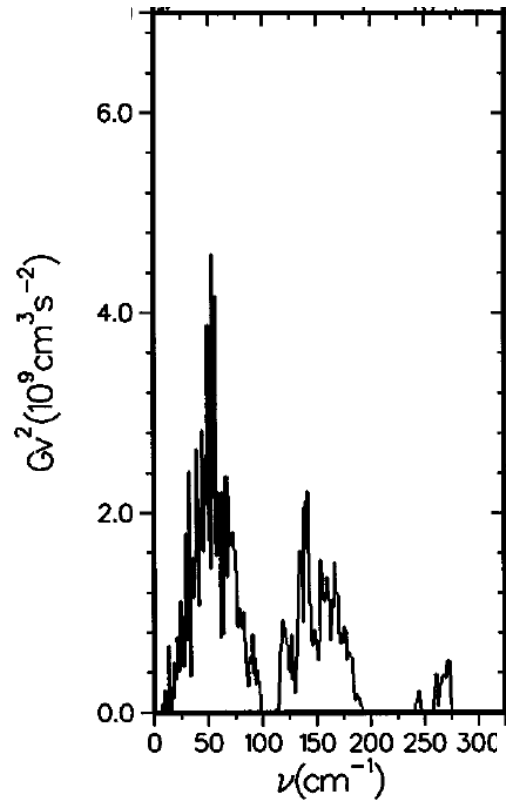
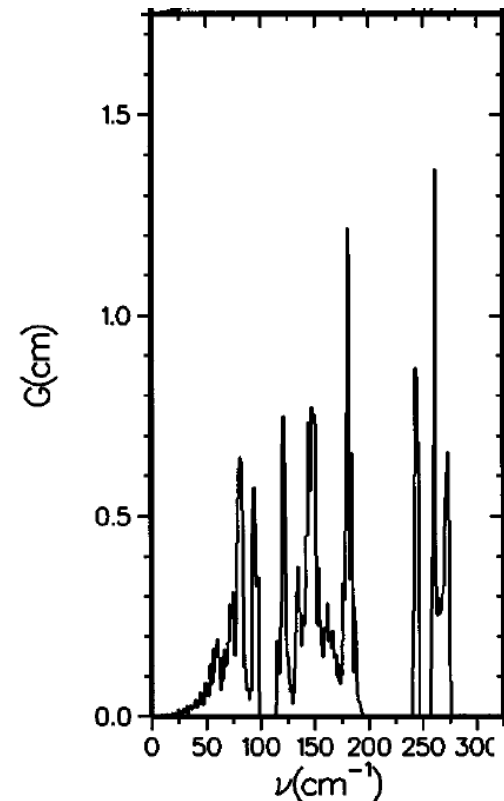

Velocity factor weights low lying acoustic phonons most strongly.

Flat optic branches make little contribution.

Addition of flat branches in the acoustic energy range can scatter leading to lower thermal conductivity (Slack, Cahill – rattling ion).

Science (2008)

High-Thermoelectric Performance of Nanostructured Bismuth Antimony Telluride Bulk Alloys

Bed Poudel,^{1,2*} Qing Hao,^{3*} Yi Ma,^{1,2} Yucheng Lan,¹ Austin Minnich,³ Bo Yu,¹ Xiao Yan,¹ Dezhi Wang,¹ Andrew Muto,³ Daryoosh Vashaee,³ Xiaoyuan Chen,³ Junming Liu,⁴ Mildred S. Dresselhaus,⁵ Gang Chen,^{3†} Zhifeng Ren^{1†}

Ball milled powder → reduced κ_l

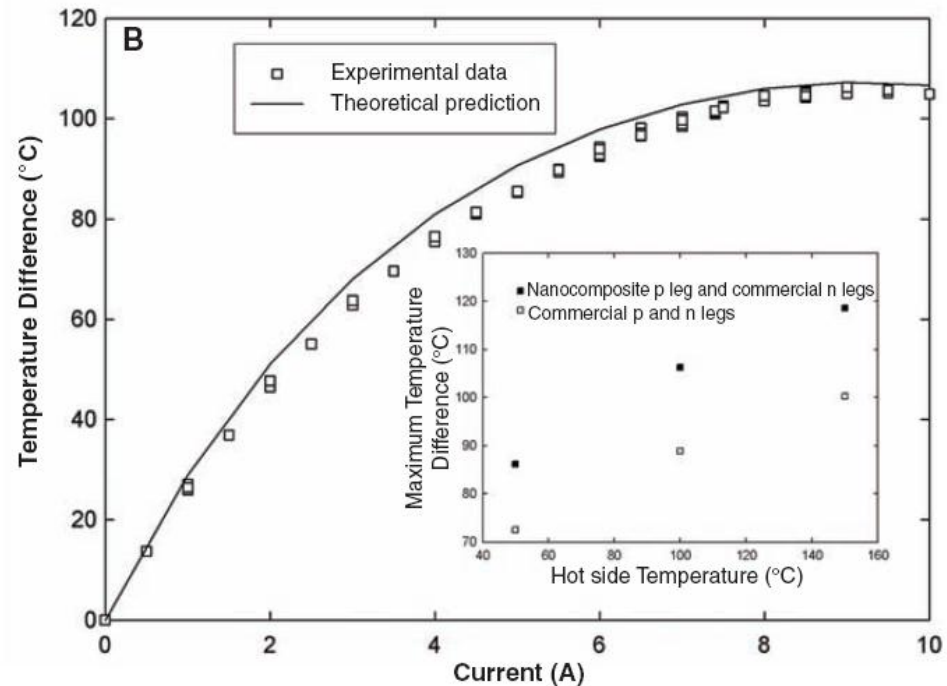
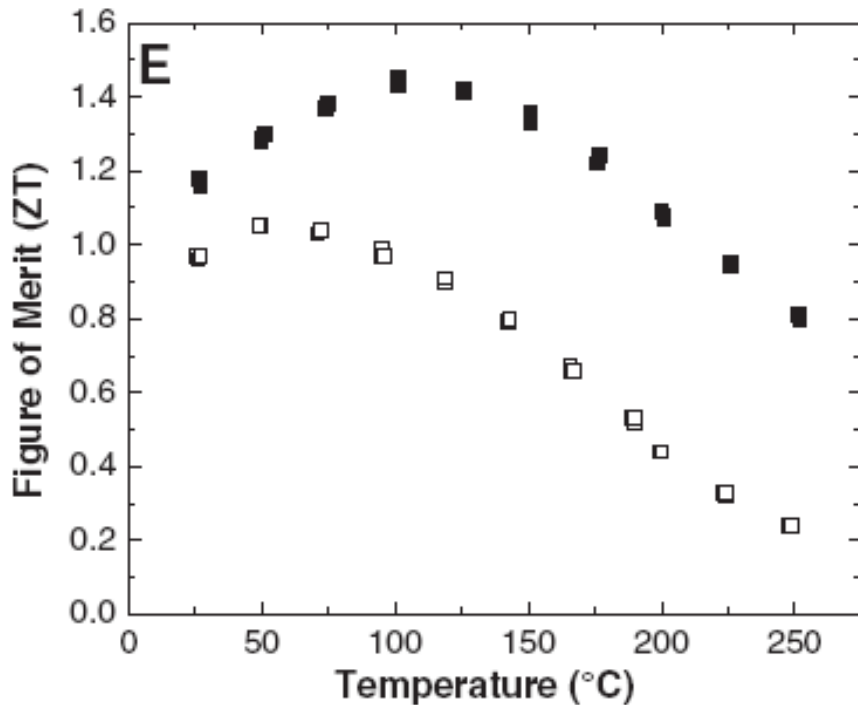
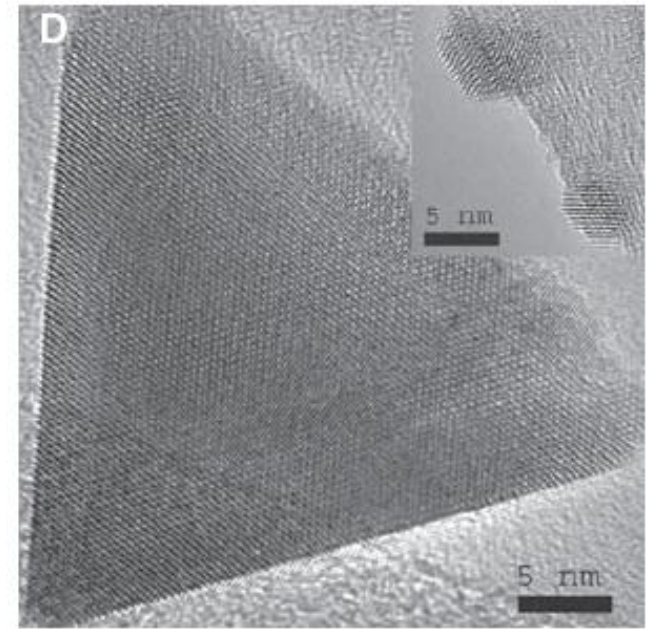

Designer Materials



Packard-Bell

Requirements:

- Need a materials class where the desired function is thought to exist.
- Need to know what the chemical degrees of freedom are (a big simplification).

Materials Design:

- Establish rules to predict the dependence of properties on the “knobs”.
- Use these rules, and experiment/theory to find desired compositions.

High ZT Zintl Phases

- These are generally thermoelectric materials with an anionic metallic/covalent network stabilized by cations.



- ...

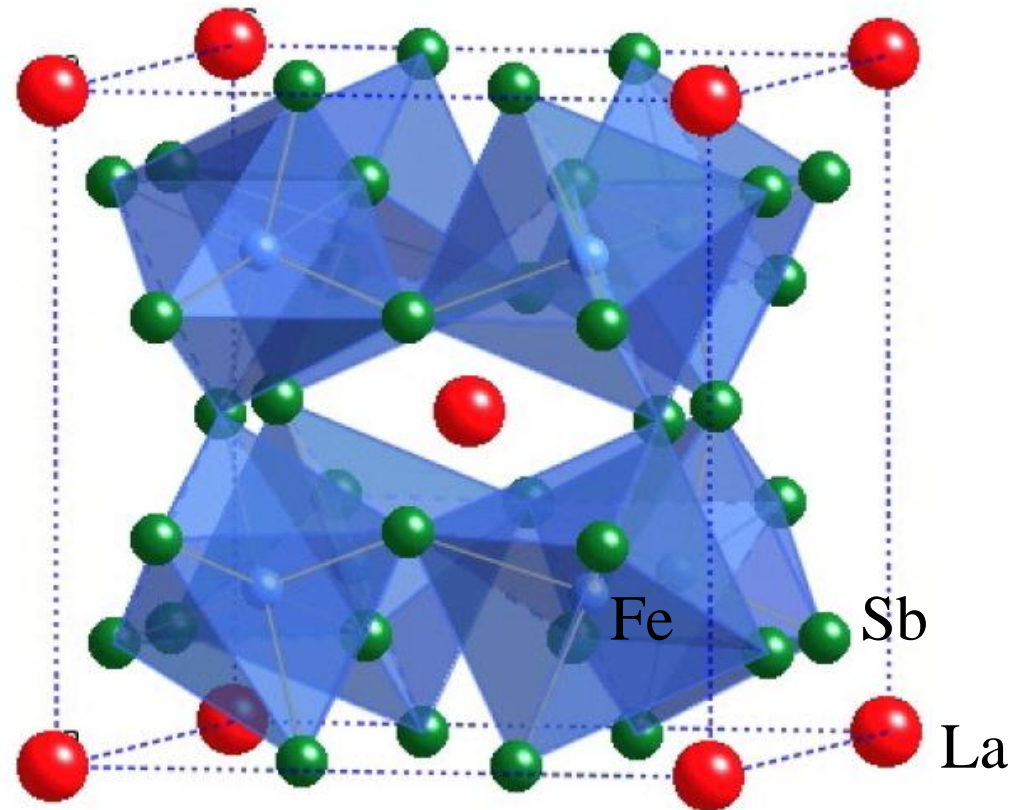

Filled skutterudite (Sales)

(FILLED) SKUTTERUDITE STRUCTURE

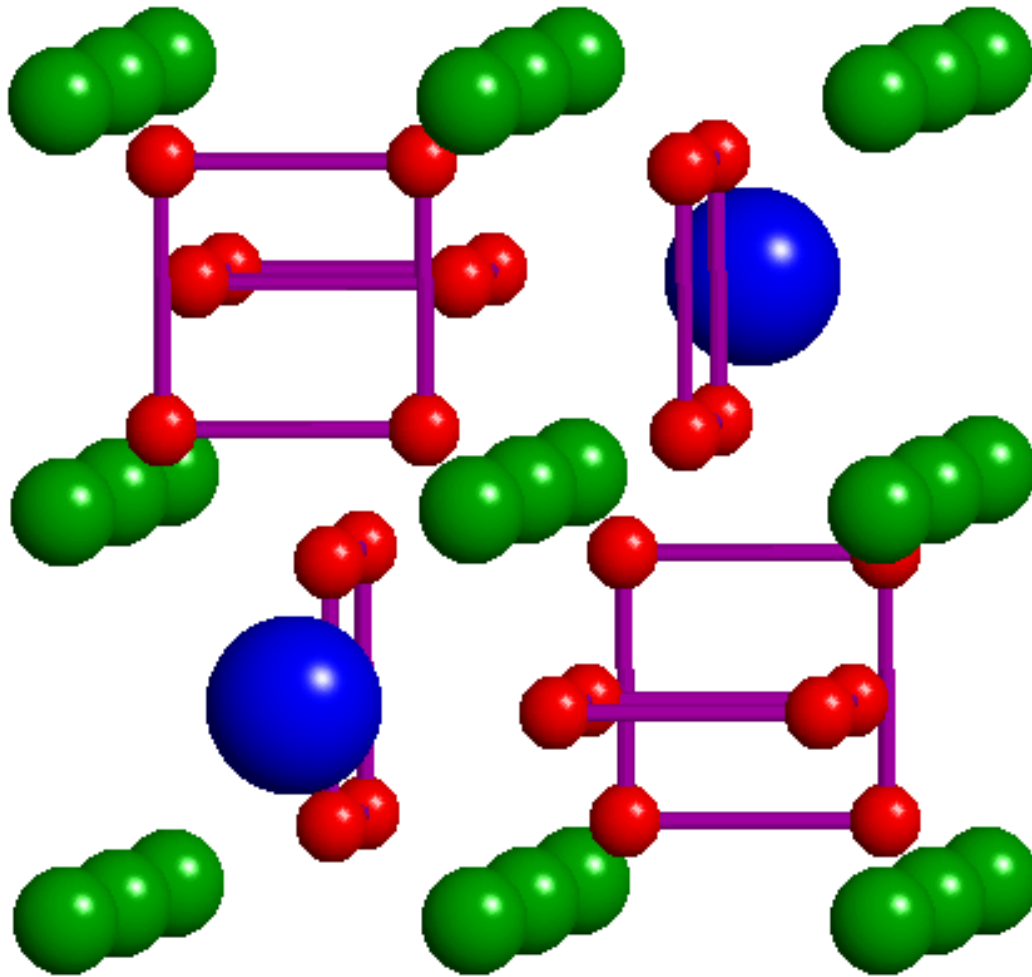

Prototype: CoSb_3

really $\square\text{Co}_4\text{Sb}_{12}$

“Holes”, \square can be filled with, rare earths, e.g. \rightarrow

$\text{LaFe}_4\text{Sb}_{12}$

Early measurements characterize as moderate ($\sim 1\text{eV}$) gap semiconductors.

SKUTTERUDITE BAND STRUCTURE

CoSb₃ (IrSb₃ is similar):

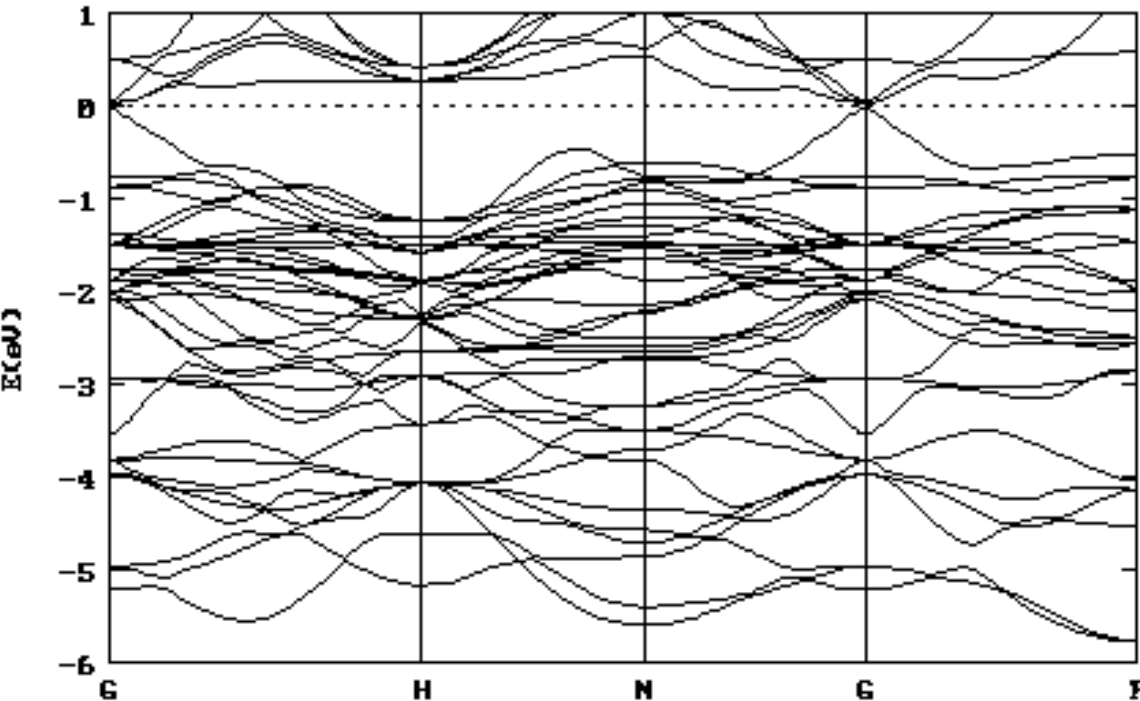

← Light non-parabolic (linear) valence band.

- Heavy degenerate c.b. highly favorable

Kinetic Transport:

- parabolic: $S/T \propto n^{-2/3}$
- linear: $S/T \propto n^{-1/3}$

Band structure not favorable for p-type TE.

Very good for n-type.

BAND STRUCTURE OF BINARIES

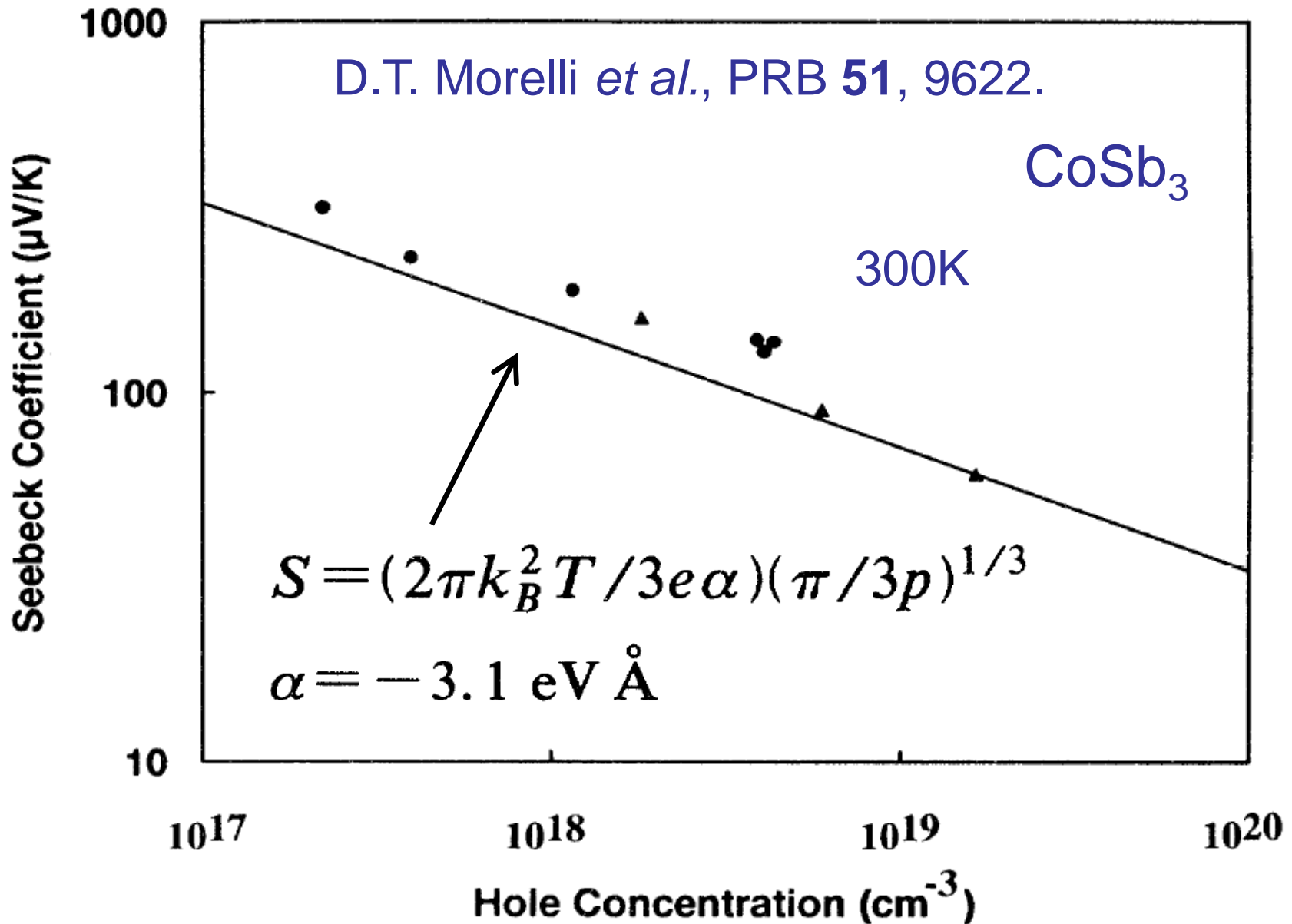

RARE EARTH FILLED SKUTTERUDITES

•Antimonides:

- Strongly reduced κ_l (~ 15 mW/cmK)
- High S and high ZT in $\text{La}(\text{Fe},\text{Co})\text{Sb}_{12}$, $\text{CeFe}_4\text{Sb}_{12}$ and others.

$\text{La}(\text{Fe},\text{Co})_4\text{Sb}_{12}$

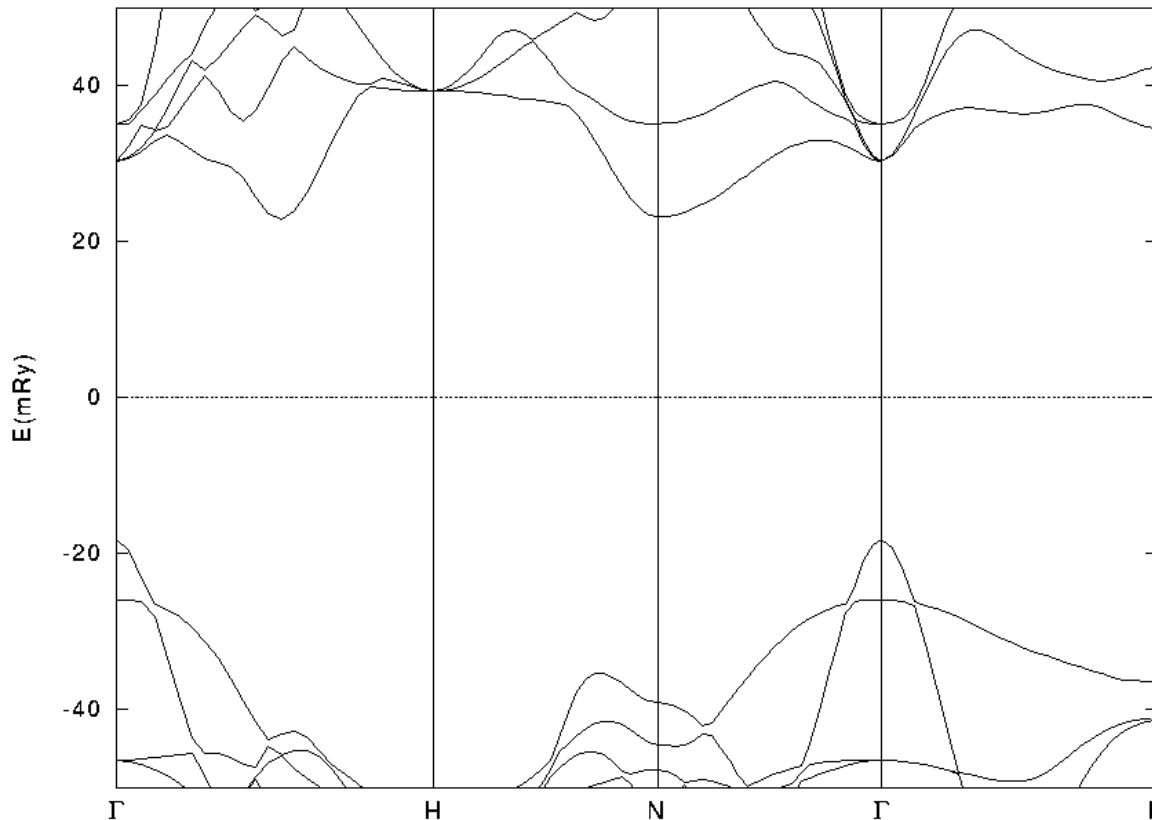

Light band is pushed down near to heavy band onset.

➔ Mechanism for high S

➔ La vacancies scatter

Multiple heavy bands for *n*-type

Light – Heavy mixture for *p*-type

Recent Experimental Results on Skutterudites

e.g. X. Shi et al., APL (2008): $(\text{Ba}_x\text{Yb}_y)\text{Co}_4\text{Sb}_{12}$:

- Multiple filling with different atoms strongly reduces lattice thermal conductivity.
- Evidence for bi-polar conduction with low filling. Filling and doping level are connected.

Is there a way to have high, possibly multiple filling, and at the same time high $S(T)$?

Can p-type ZT be improved?

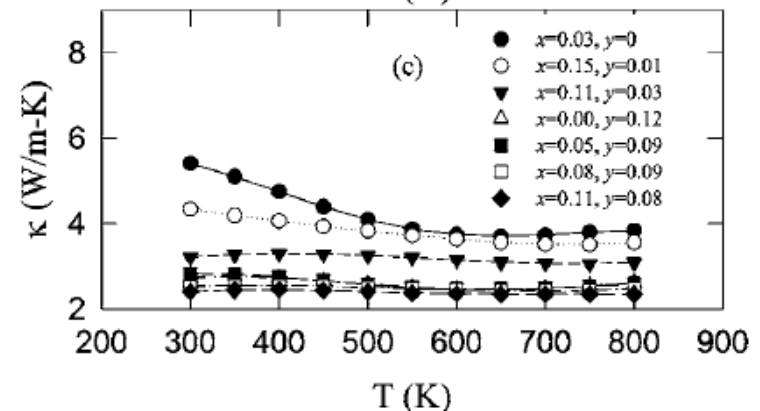
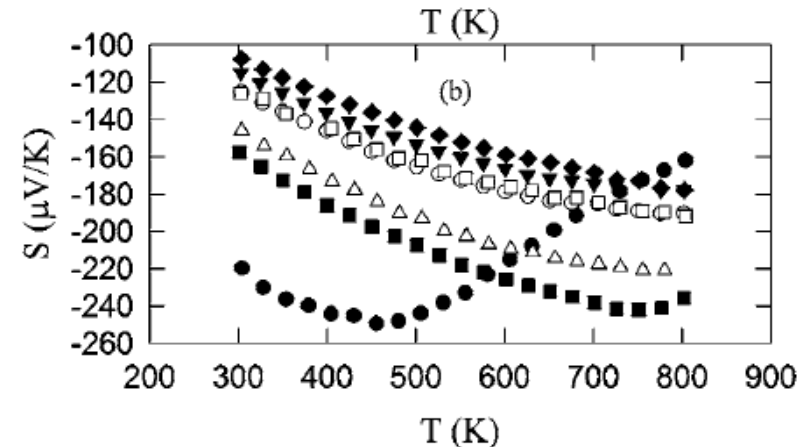
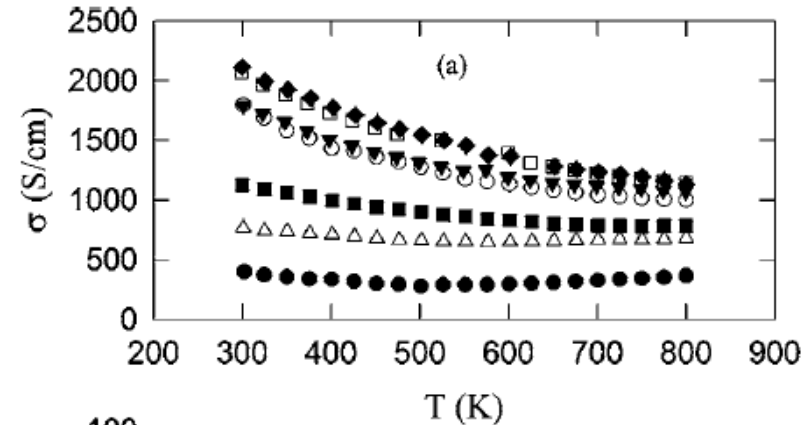
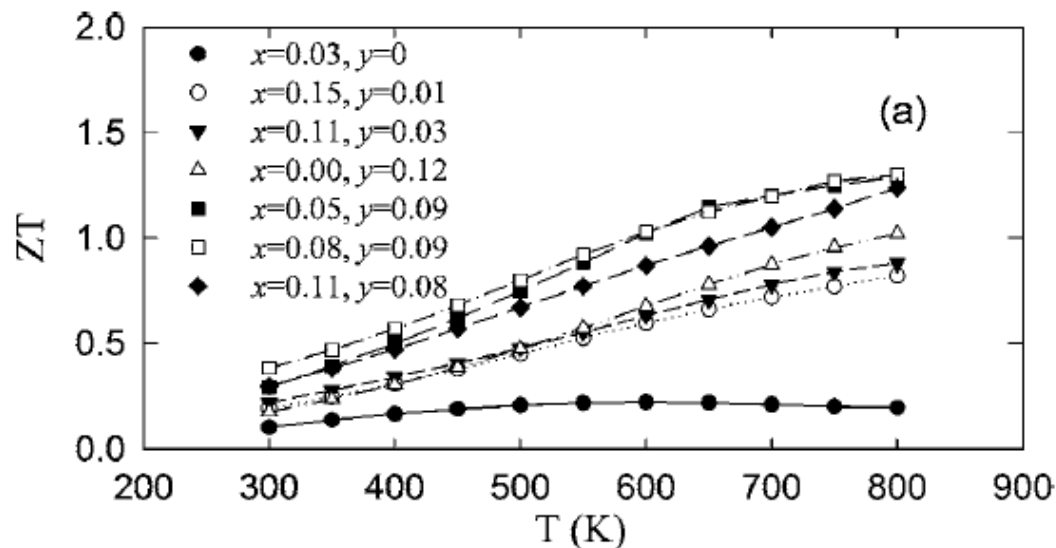

Can we use the transition element?

Use this site

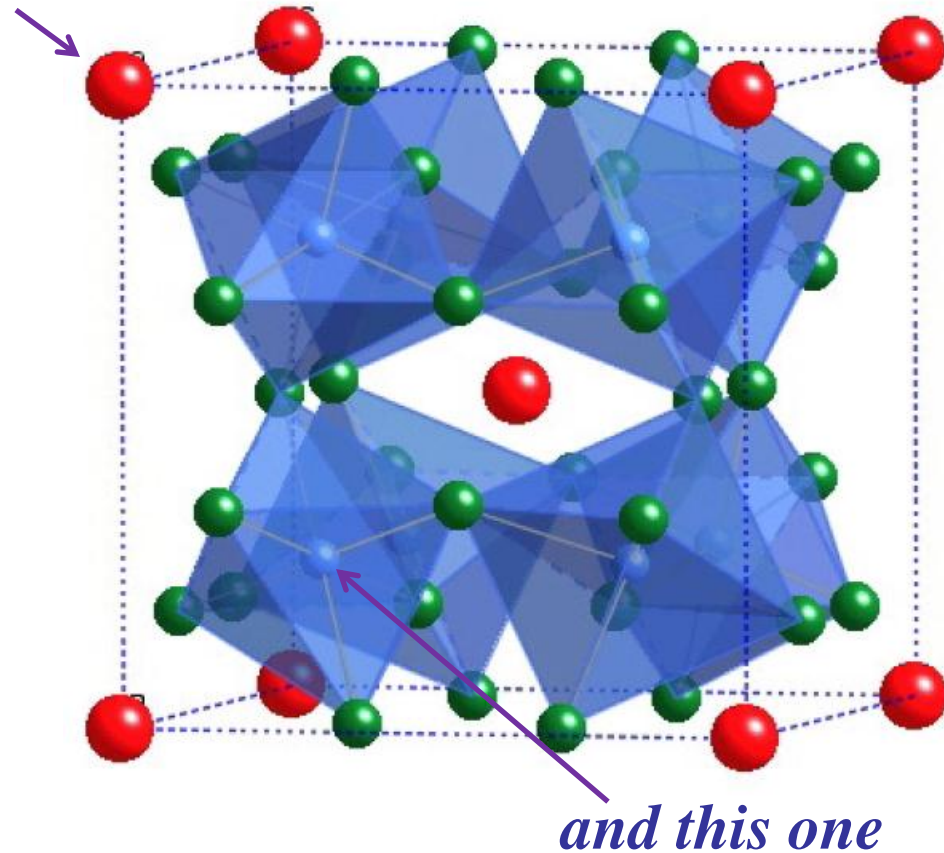

We want to control gap opening, lattice thermal conductivity, and carrier concentration.

- Replace Co by $\text{Fe}_{1-y}\text{Ni}_y$ or perhaps $\text{Fe}_{1-y}\text{Co}_y$ with y selected for a lower electron count
- Use a high filling fraction of electro-positive elements.
 - *e.g.* $\text{Ae}_x\text{Fe}_{4-y}\text{Ni}_y\text{Sb}_{12}$
 - Low cost is desirable.

High filling \rightarrow large gap opening and low thermal conductivity

Control of carrier concentration on metal site \rightarrow high thermopower

Band Structure

- *Ae* filling opens a sizable gap and yields heavy/light valence band structure → favorable for *both* *p*- and *n*-type.
- Mitigates bi-polar reduction of $S(T)$ for *n*-type.
- Ni works like Co (Ni is much cheaper)

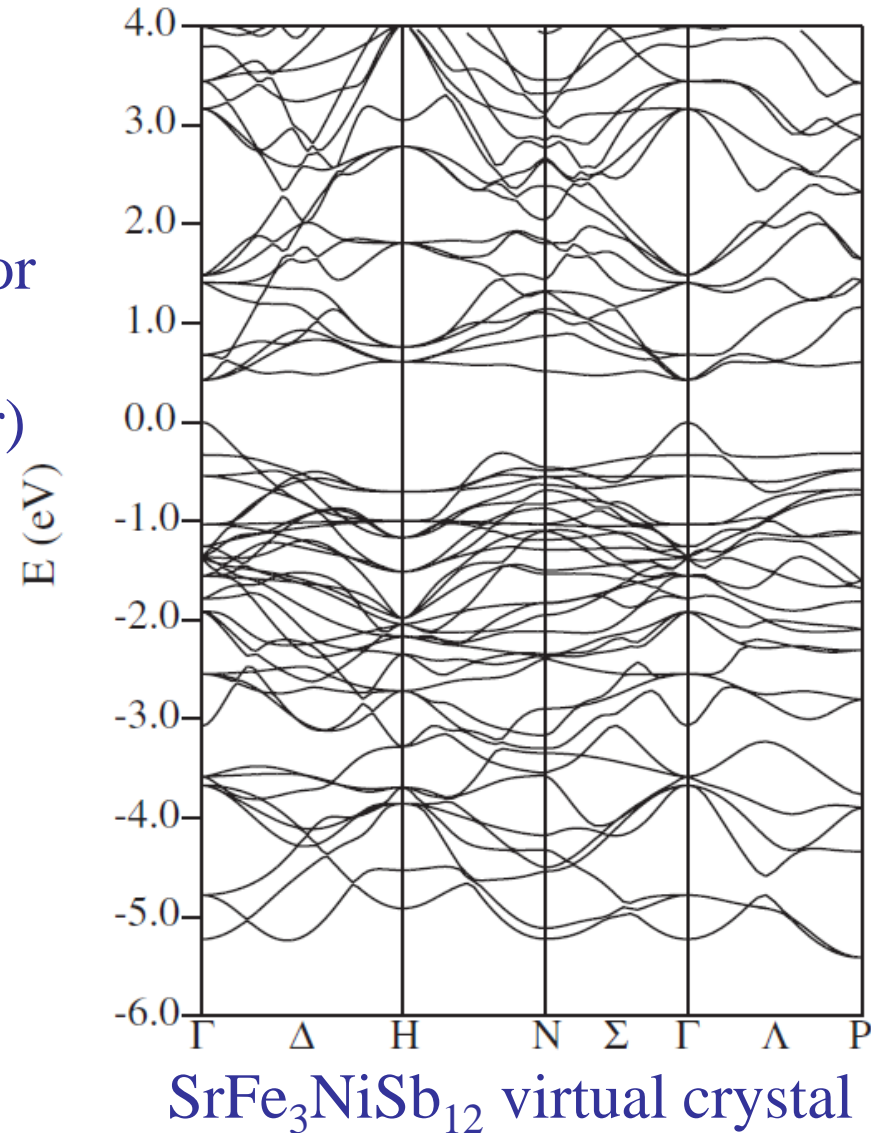
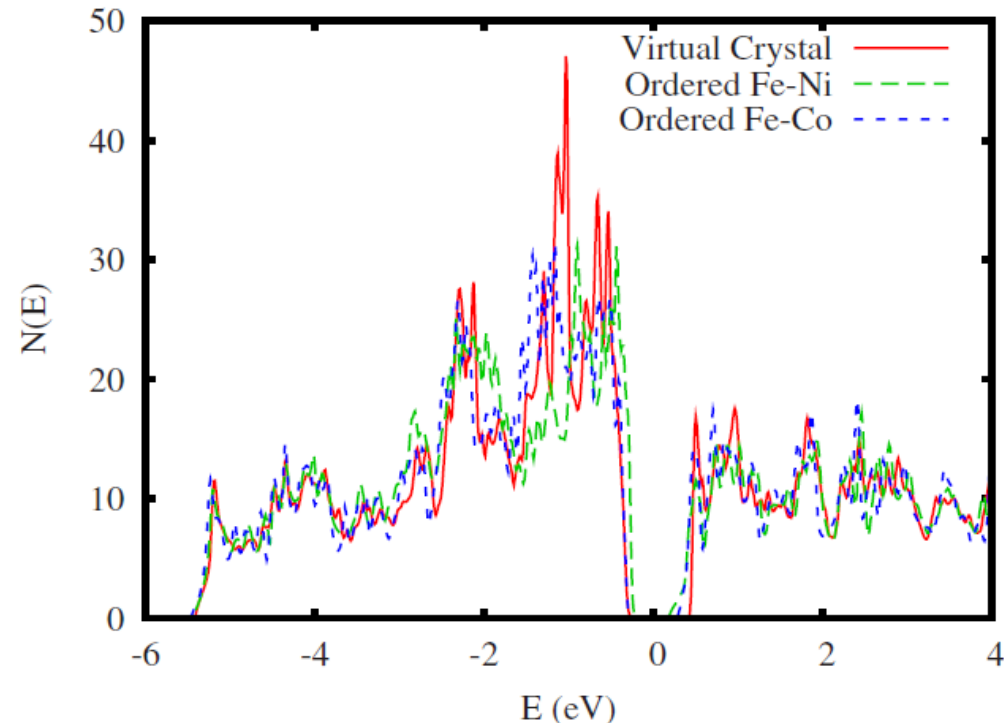

Transport

- Alkaline earths offer weaker scattering than rare earths (lower charge, no f-electrons).
- Best currently known skutterudites are better for n-type than p-type.
- We find that they can be good thermoelectrics, including p-type.

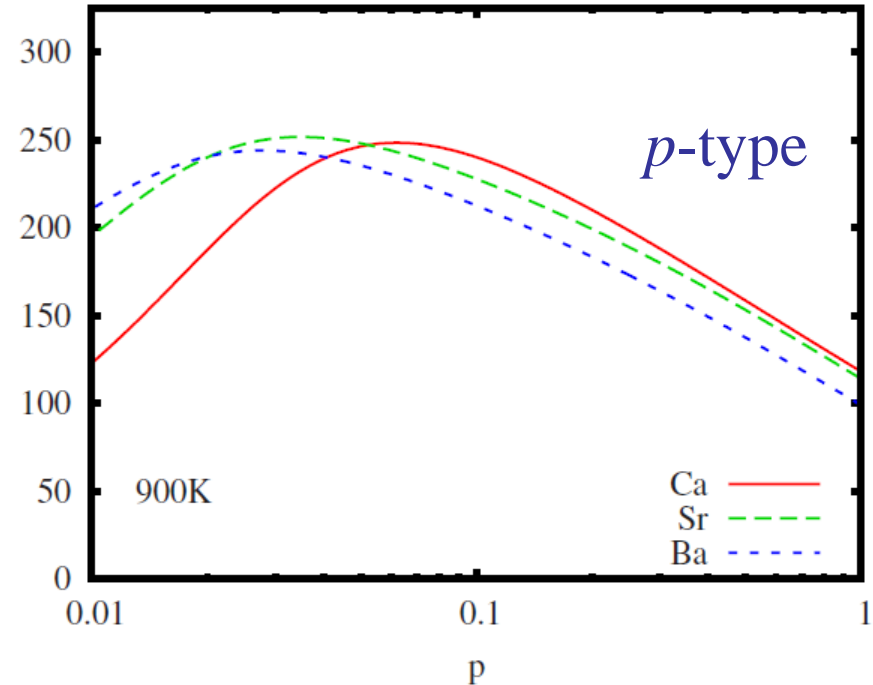
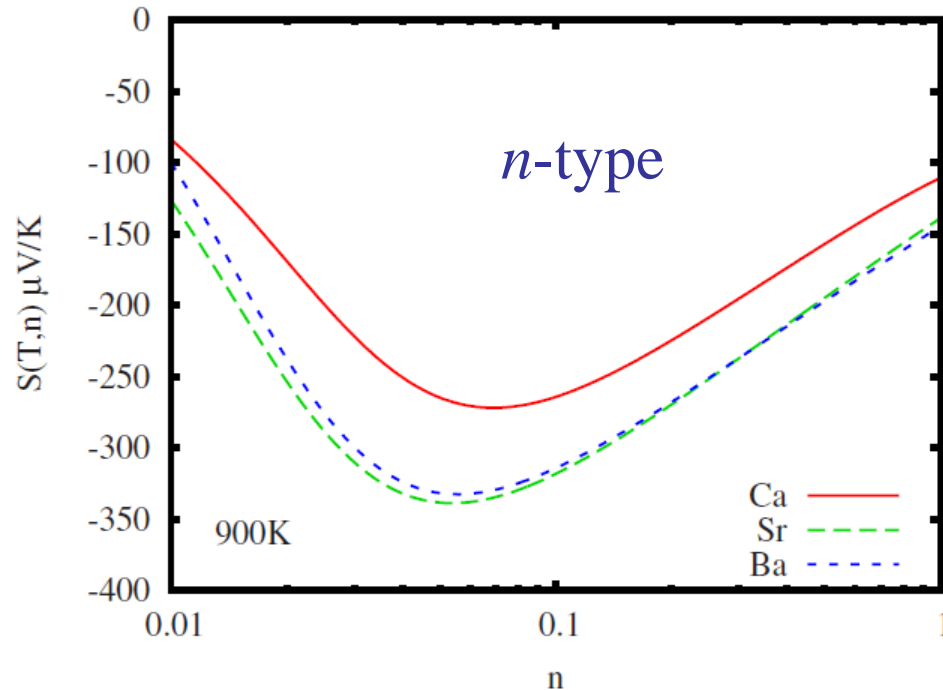

- Phonon calculations (not shown) \rightarrow May be possible to mix alkaline earths to lower thermal conductivity.

Transport – Effect of Filling

- Unfilled skutterudite CoSb_3 vs. Ae filled skutterudite (compensated on transition metal site).

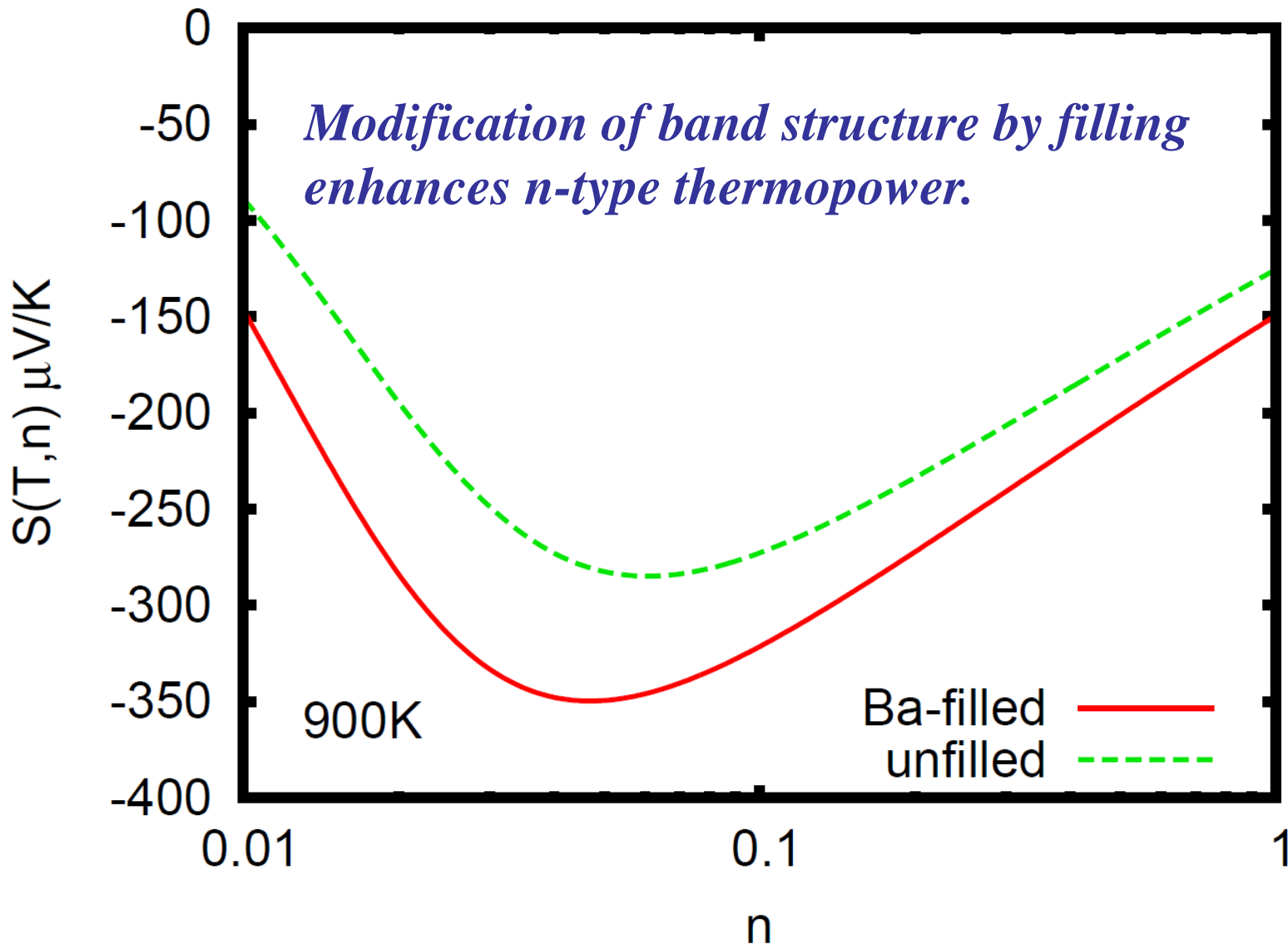

PbTe

- PbTe has simple cubic rock-salt structure with two atoms per unit cell. Well packed, well coordinated structure.
- Many excellent thermoelectrics are based on PbTe:
 - Artificial nanostructures (Harman et. al.).
 - LAST (Kanatzidis group).
 - PbTe with TI resonant enhancement (Heremans).

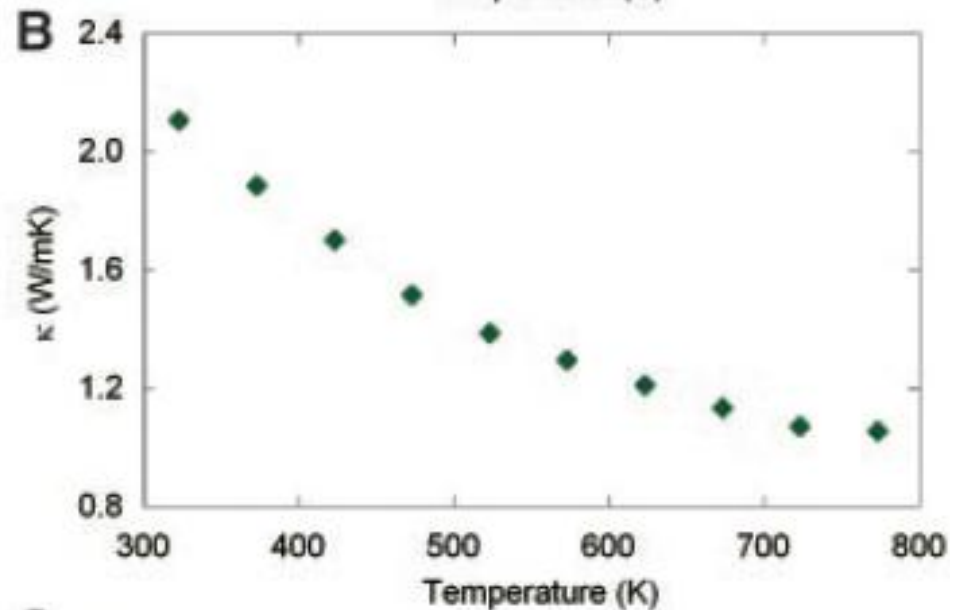
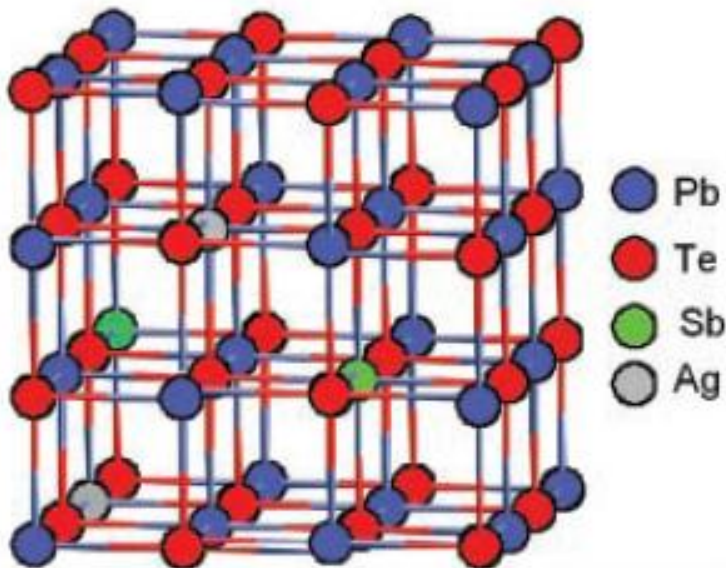

$\text{Ag}_{1-x}\text{Pb}_{18}\text{SbTe}_{20}$, Kanatzidis Group, Science, 2004.

Phonons in PbTe

a) Compressed: $a = 6.300\text{\AA}$ -2.2%

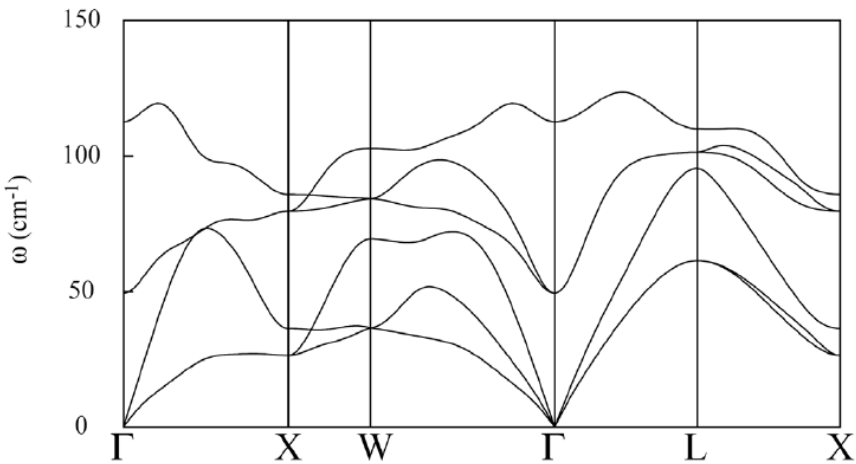

Linear response calculations → zone center soft mode with super-strong strain coupling – (longitudinal acoustic to transverse optic).

Key Points:

PbTe is near ferroelectricity.

c.f. GeTe which is ferroelectric when undoped – basis of TAGS (GeTe – AgSbTe).

b) Ambient (120K) $a = 6.4384\text{\AA}$

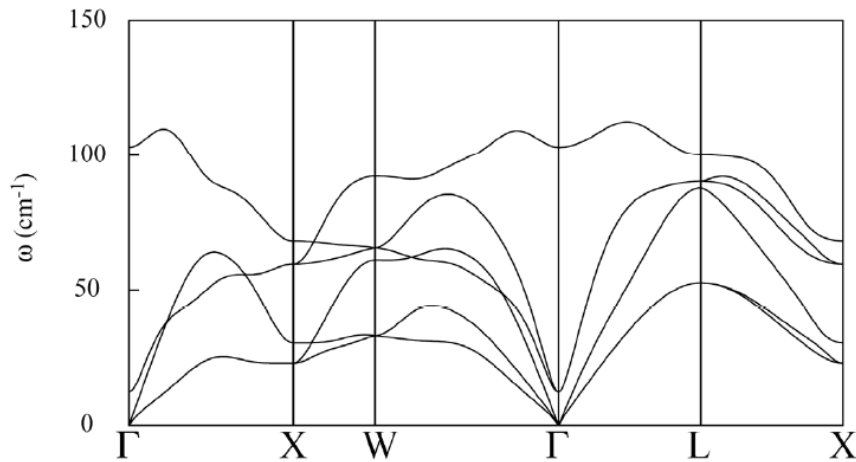

Anharmonicity

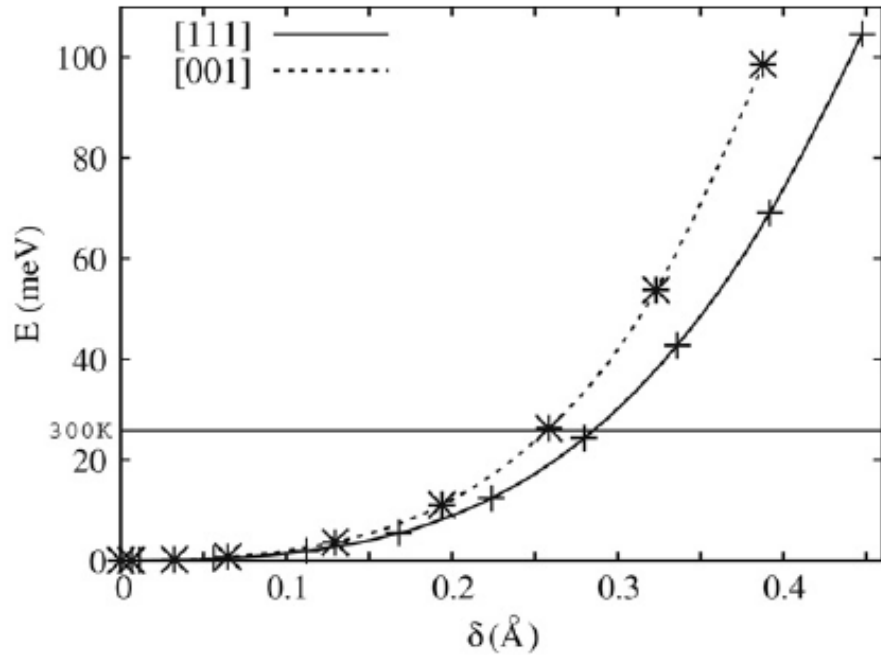

Strong anharmonic coupling between TO and LA modes

Strong anharmonicity of TO mode.

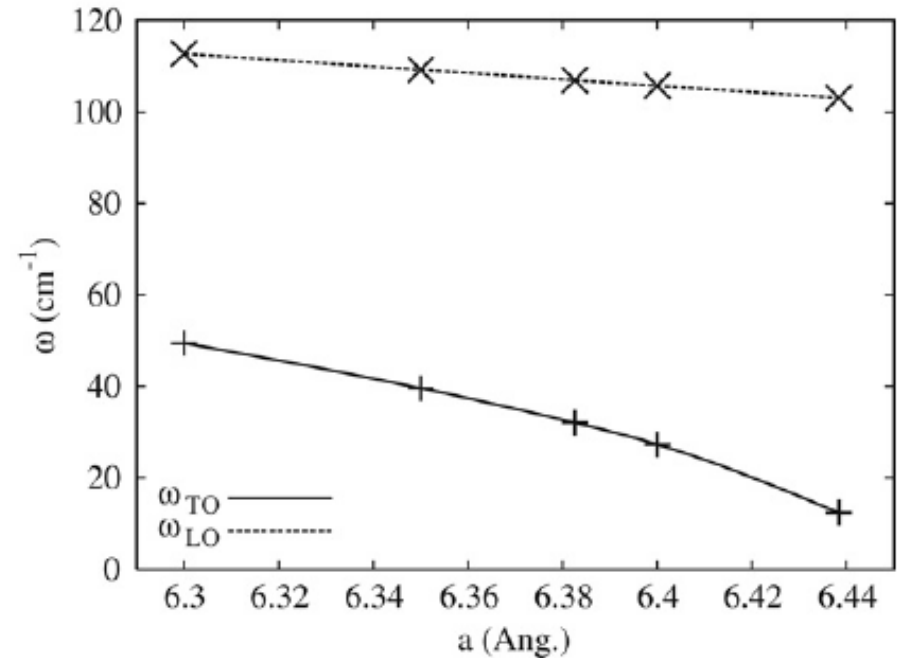

Inelastic Neutron Scattering

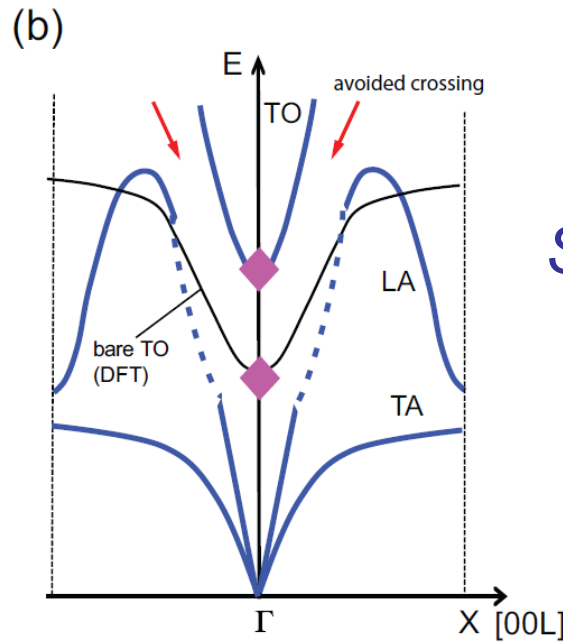
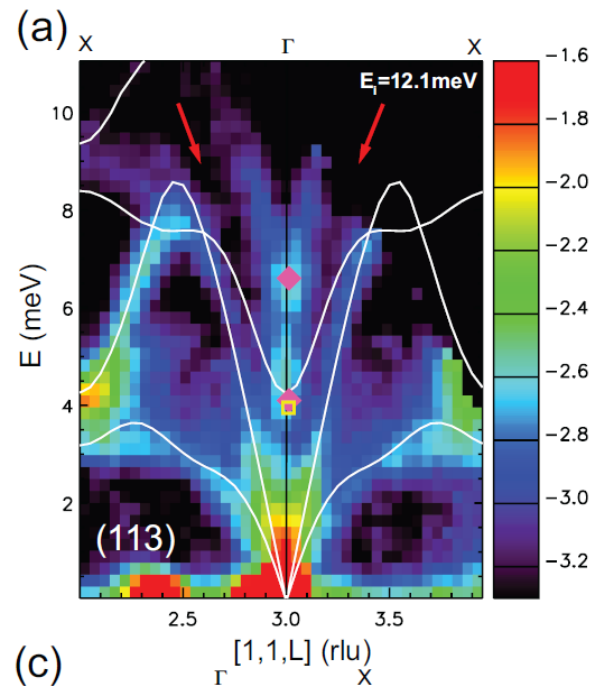

$S(\mathbf{q}, \omega)$ using SNS

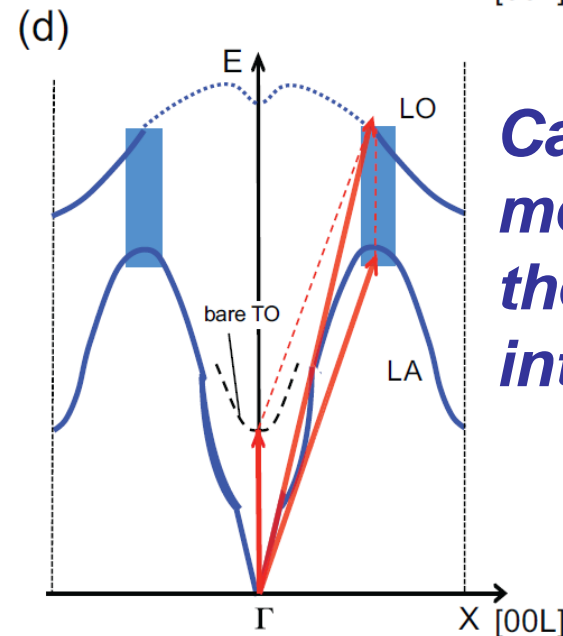
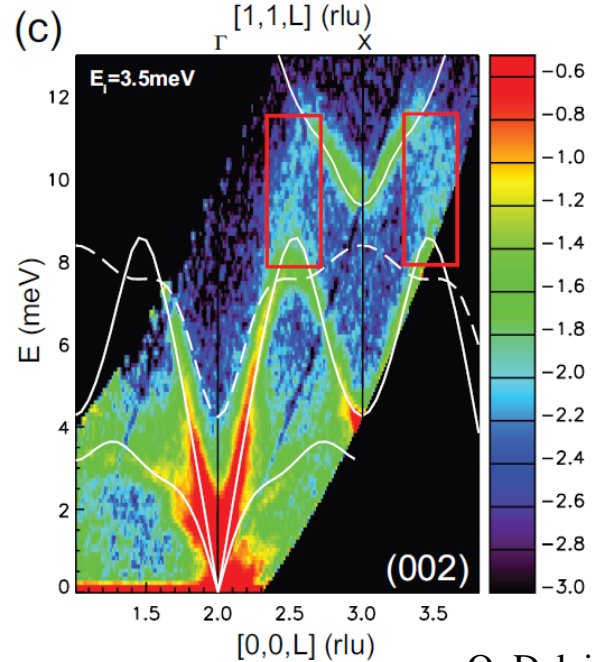

Can we engineer soft mode materials as bulk thermoelectrics or for interfaces in composites?

PbTe Band Structure

- First principles calculations

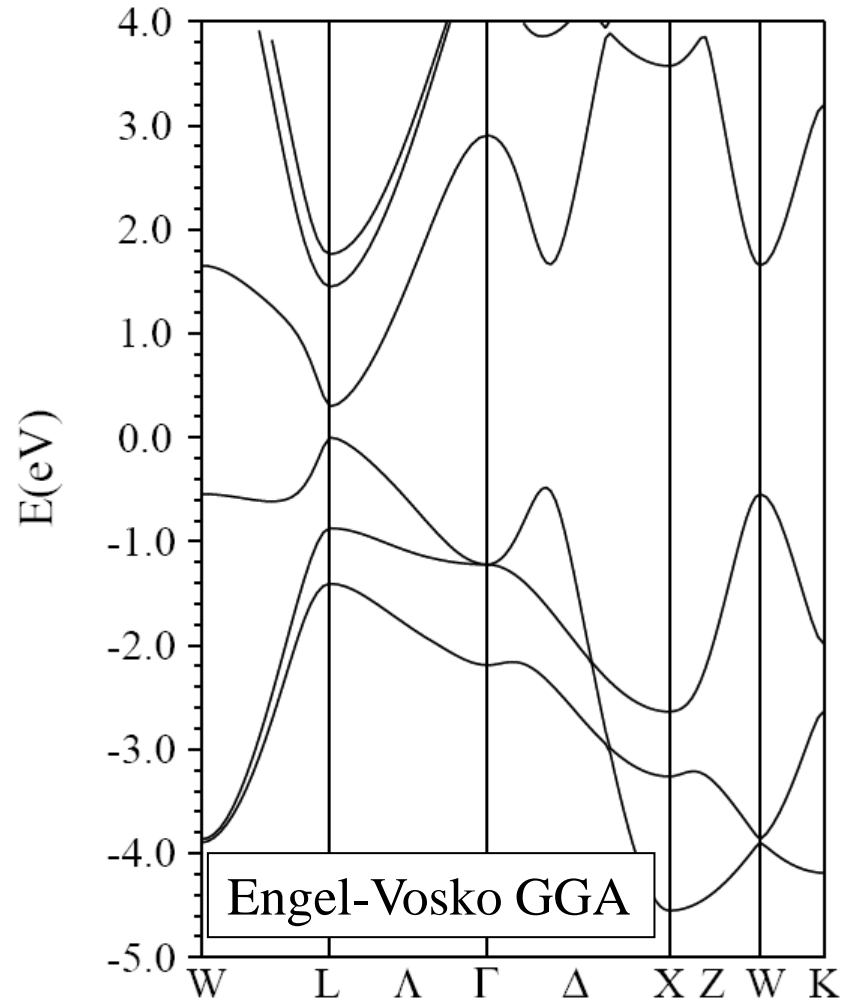

- Light mass non-parabolic band structure near the band edges.
- Becomes much heavier away from the band edge.

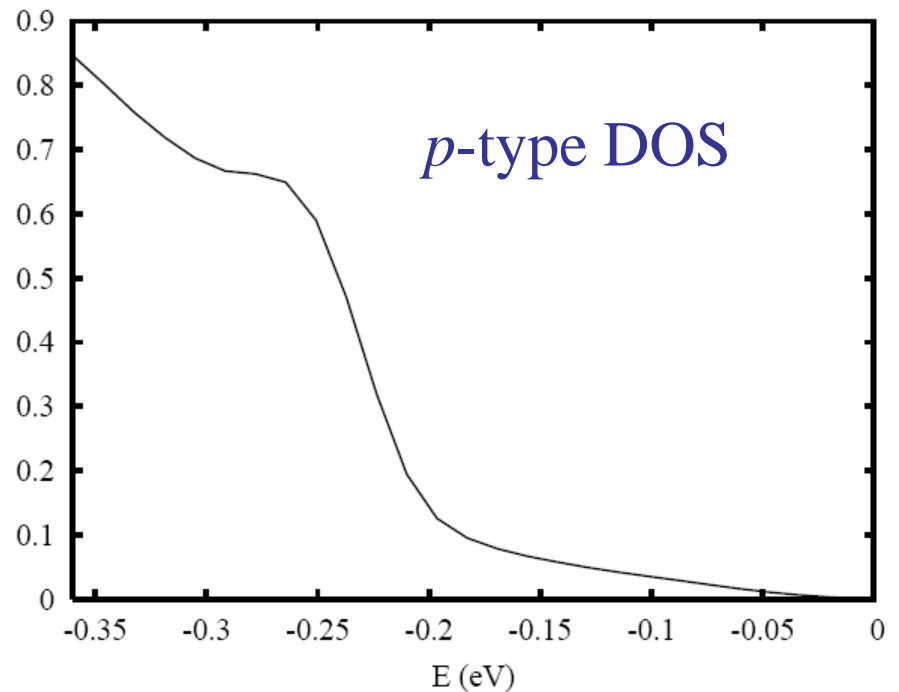

Origin of High DOS below 0.2 eV

- Hole pockets at the L-points become connected along ~ 001 (not symmetry lines).

-0.20 eV

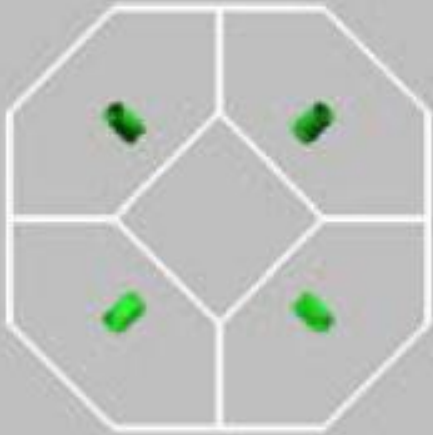

-0.25 eV

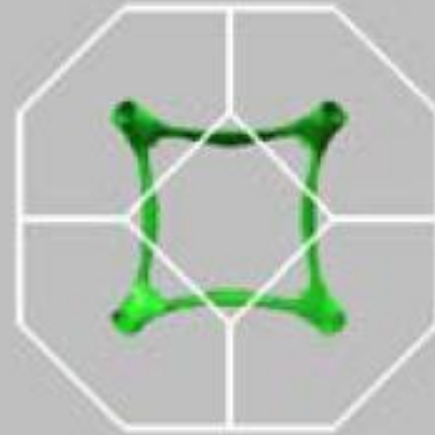

PbTe Thermopower

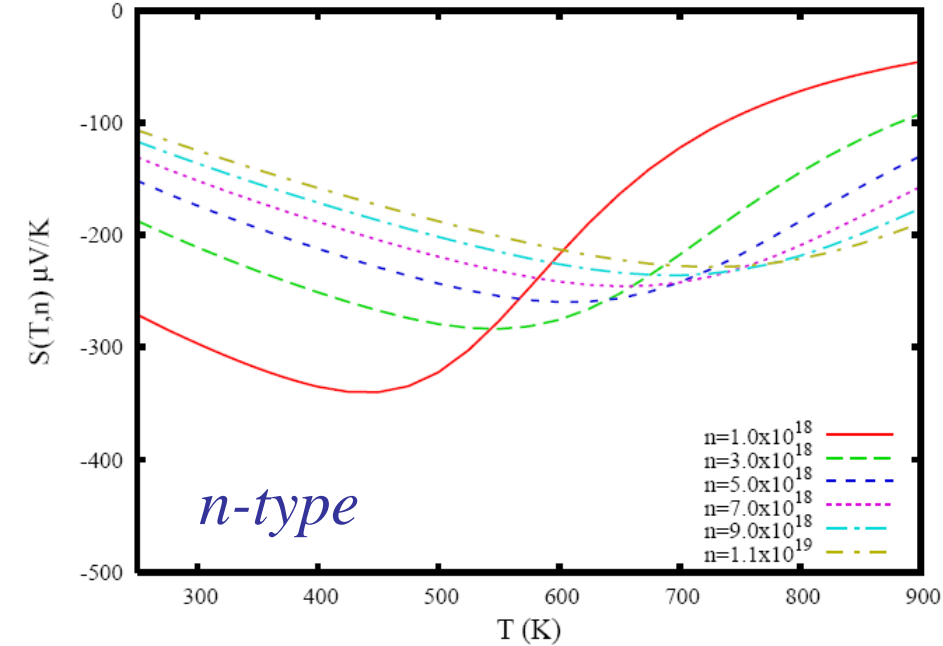
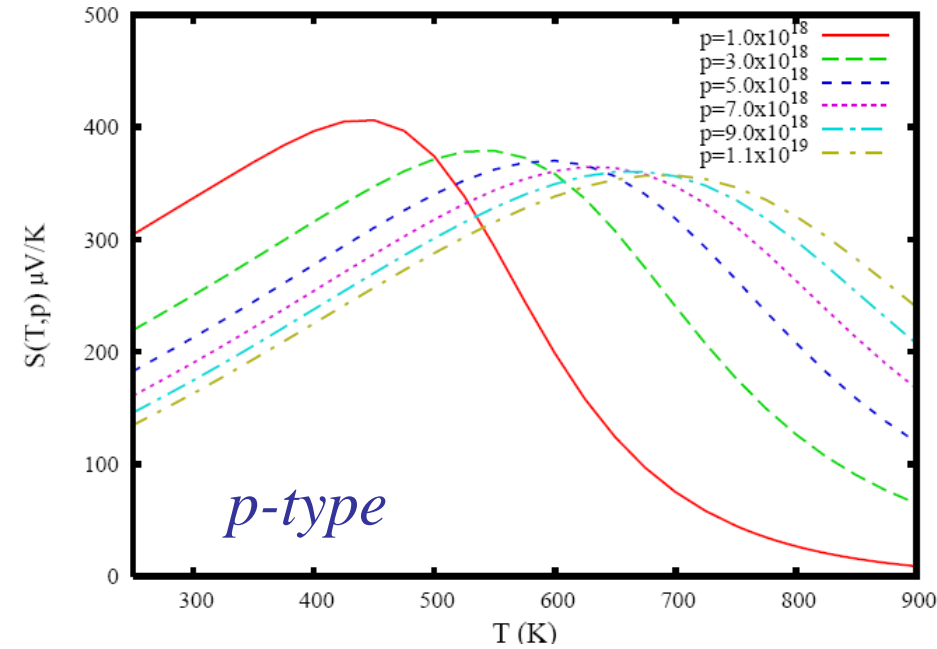

- Enhanced thermopower at high doping levels and high temperatures, especially for p -type.
- Reflects non-parabolic bands, which become heavier away from the band edge \rightarrow sampled more in thermopower at high T and p .

Comparison with Experiment

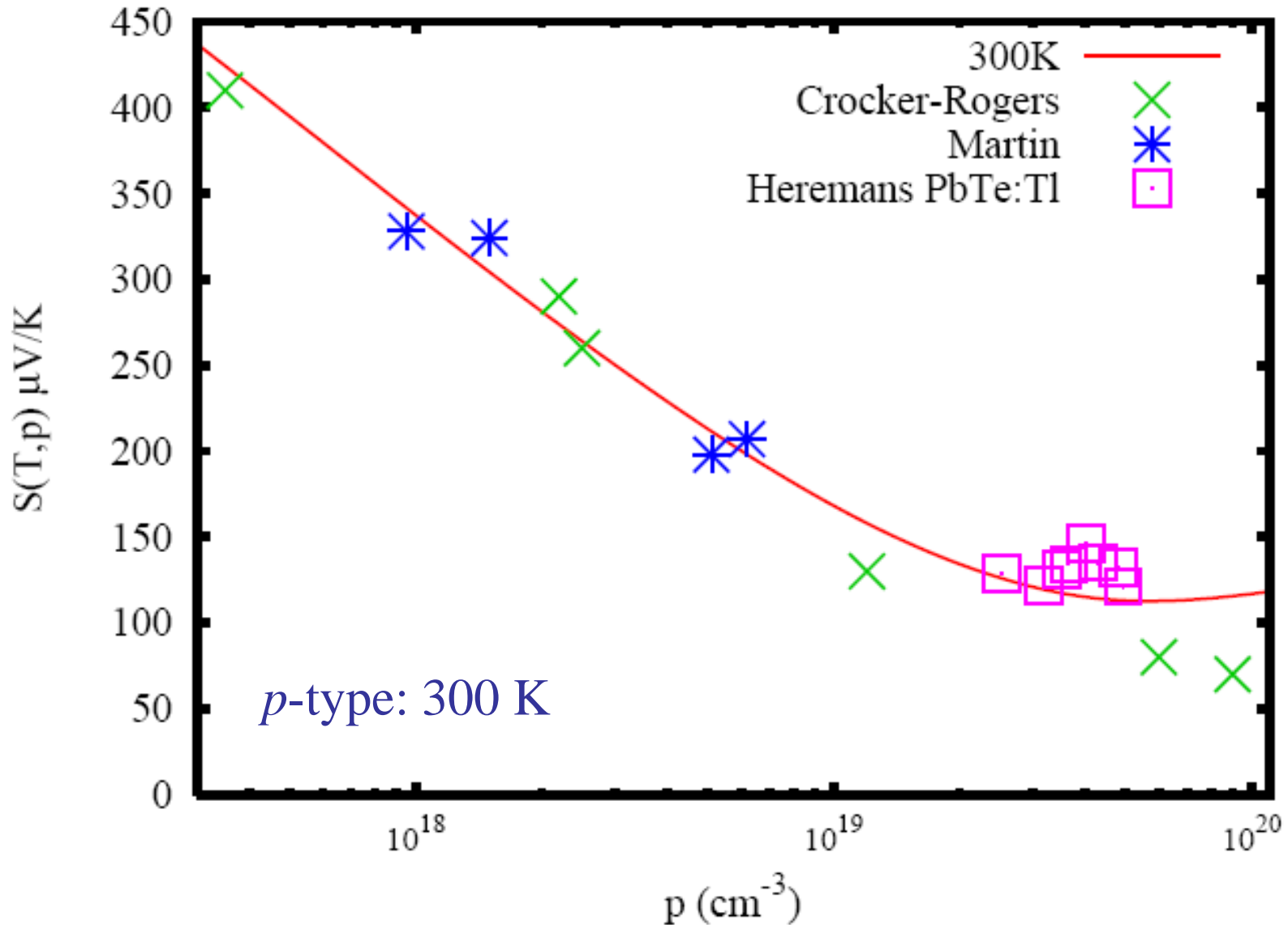

Enhancement at high p : agrees quantitatively with Hereman's data for PbTe:Tl, but not older Crocker-Rogers data (doping?)

T-Dependence at High p-Type Doping Levels

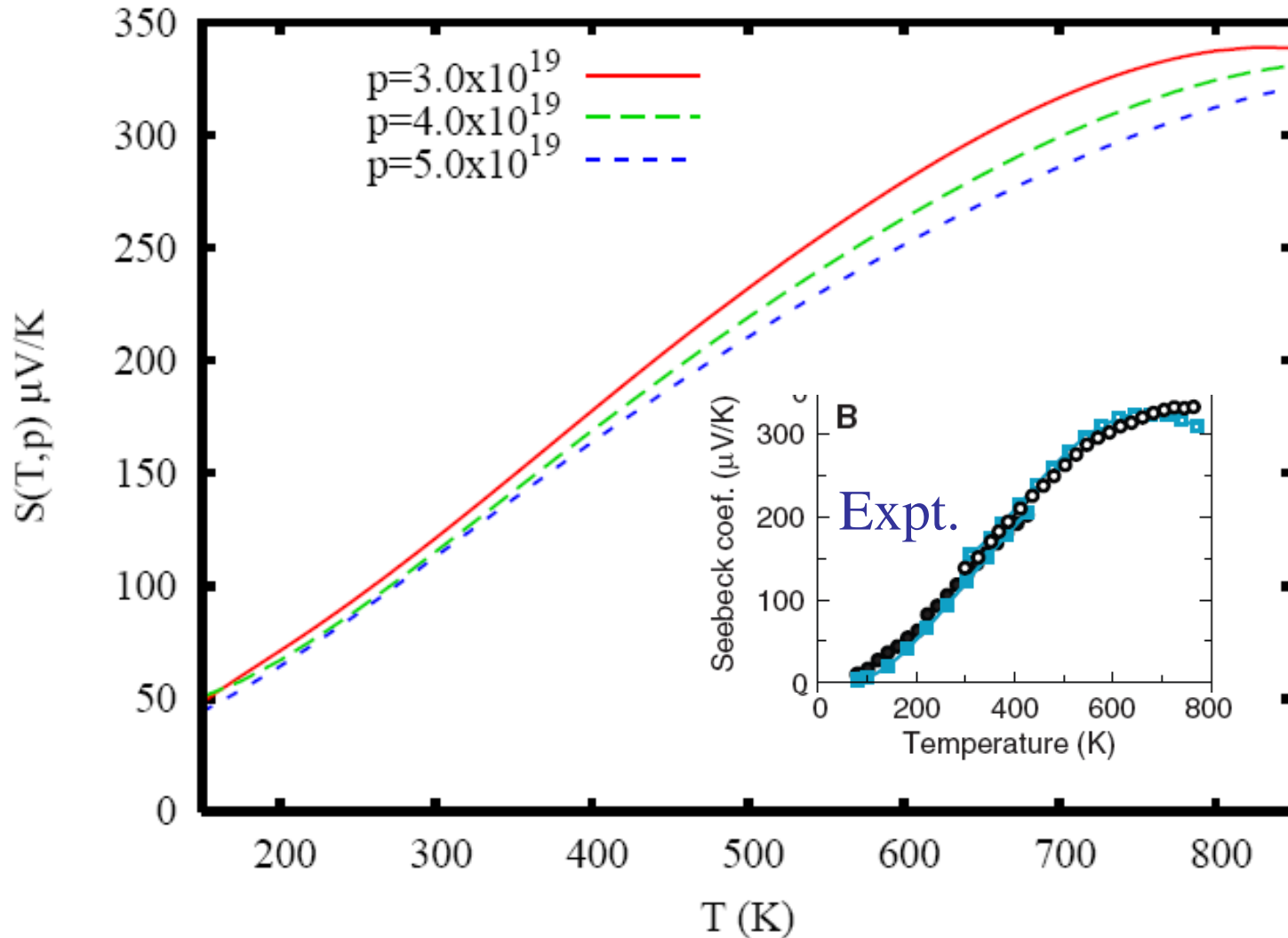

Phys. Rev. B **81**,
195217 (2010)

Similar to PbTe:Tl experimental data – may be possible to get high ZT without Tl. --- We also find behavior indicative of high ZT in p-type PbSe especially at elevated T .

Atom Probe Tomography (APT)

Ivan D. Blum and David N. Seidman (Northwestern)

PbTe: Na 1.4%, K 1.25%

Atom distribution in a 10 nm thick slice

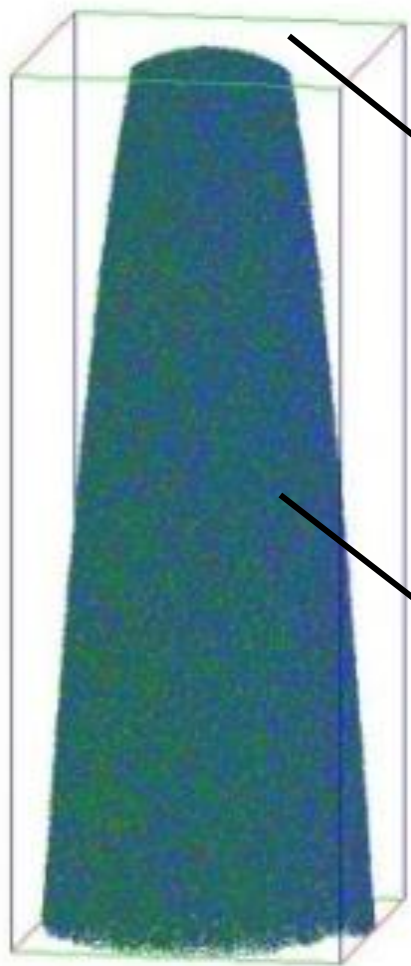

Na

K

Pb

Te

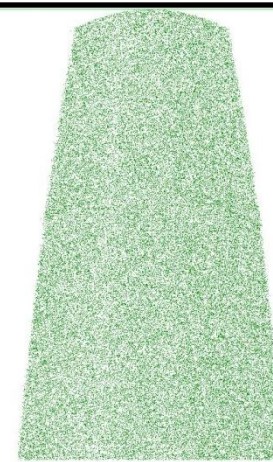
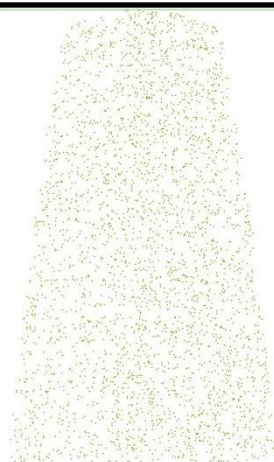
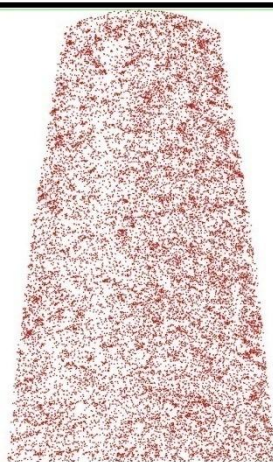

Only 5% atoms shown for clarity

- *Na has an inhomogeneous distribution*
- *Pb and Te are homogeneously distributed*

100 nm

PbSe

- Computational survey of PbTe related materials, combining Boltzmann transport & literature data.
- Found that *p*-type PbSe is a very high performance material, as good as PbTe even though it has long been thought that PbSe is inferior – issue is PbSe needs very high doping levels that were not explored before.

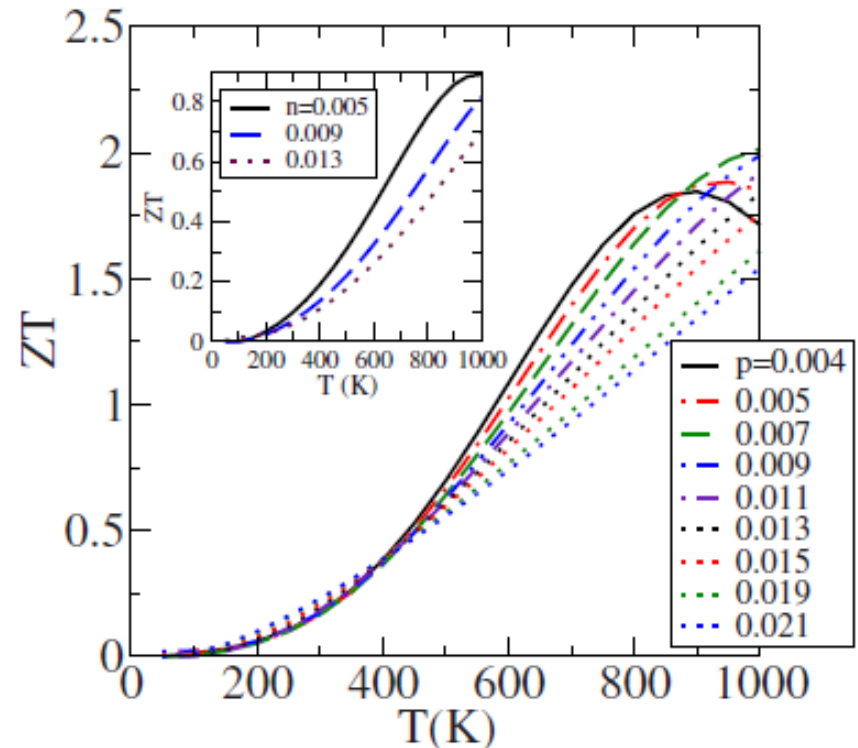
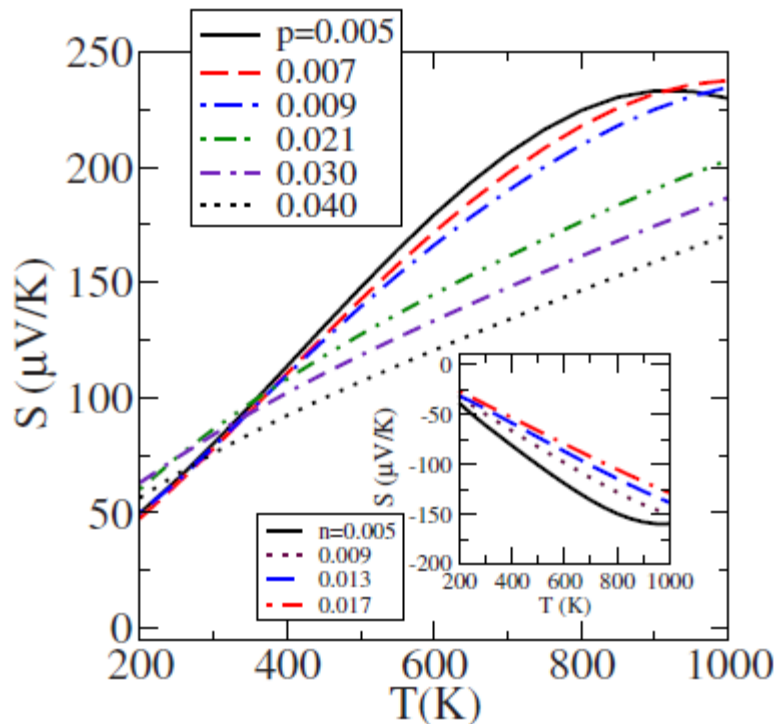

Experimental Confirmation

Graphical abstracts from recent Snyder group publications:

Pei et al., 2011

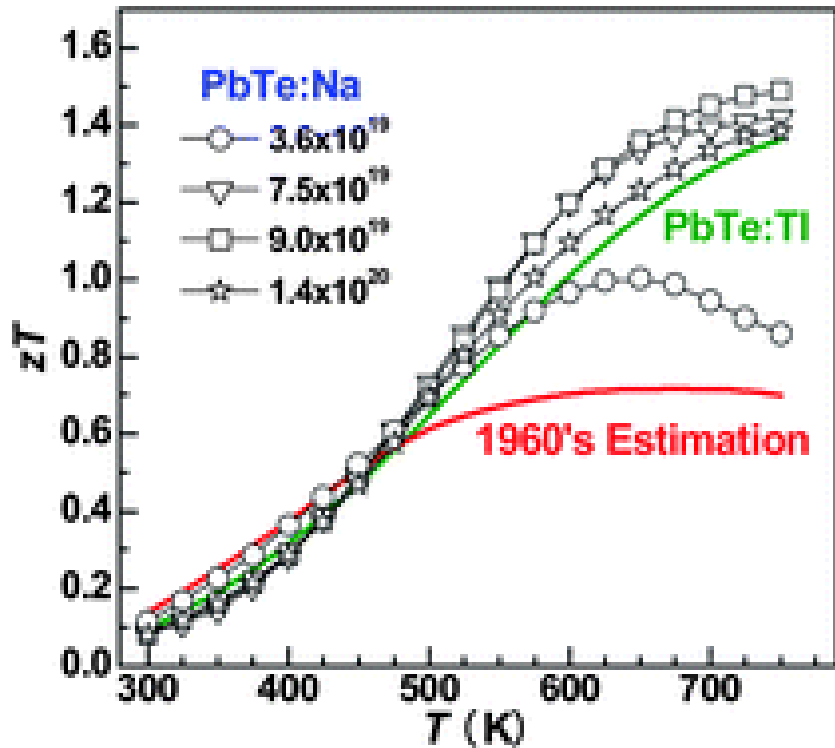

Wang et al., 2011

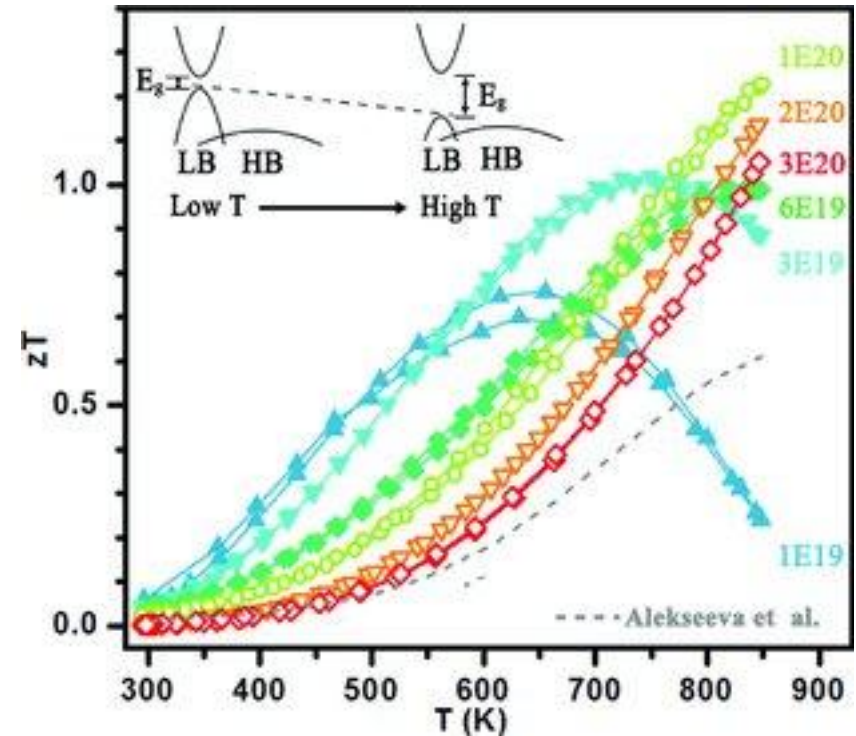

- (1) Don't need TI for high performance in PbTe.
- (2) PbSe is a high performance tellurium free alternative.

Mo₃Sb₇

- Cubic p-type thermoelectric material based on relatively inexpensive elements.

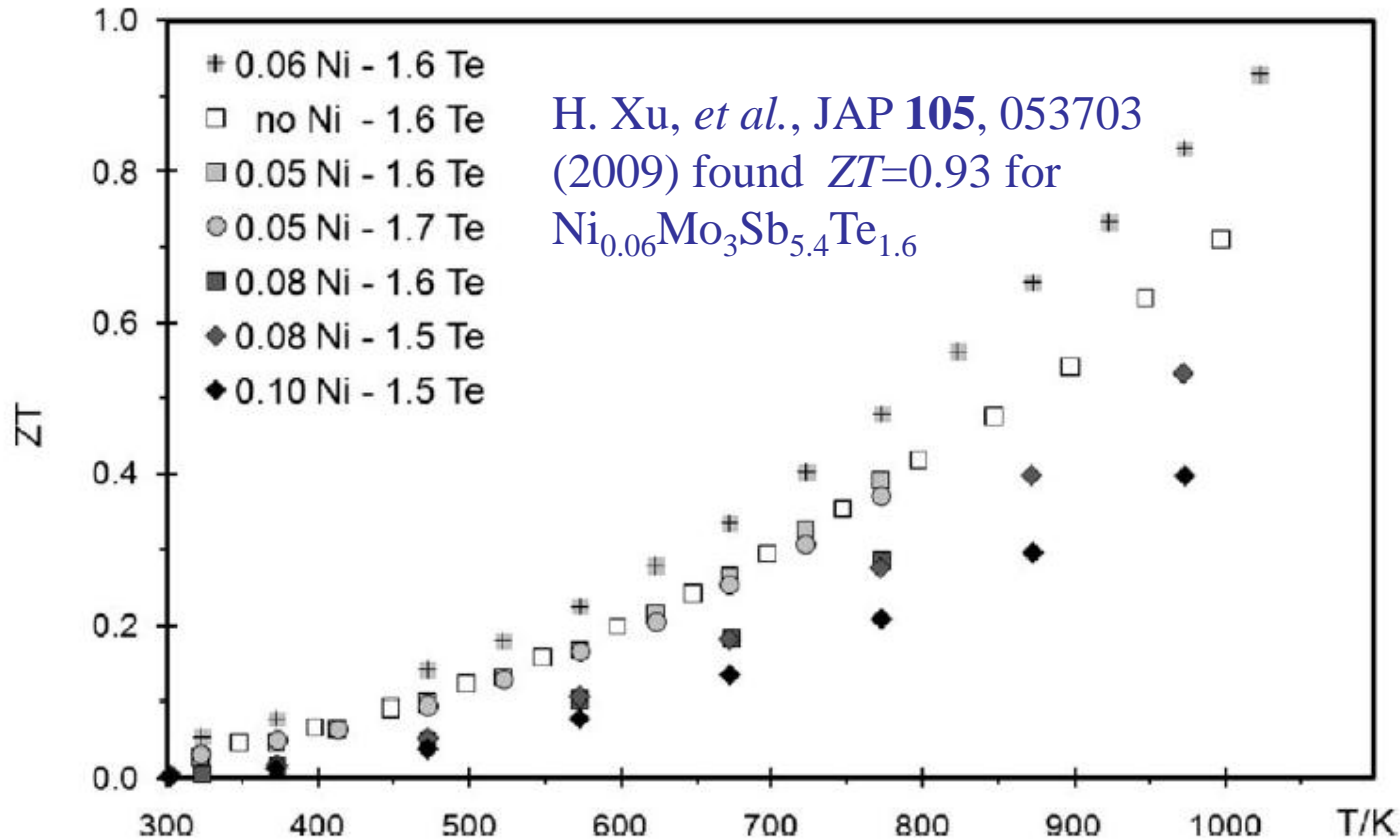

Is this optimized?

Can high ZT be obtained without Te?

FIG. 9. Thermoelectric figure of merit ZT of $Ni_yMo_3Sb_{7-x}Te_x$.

Electronic Structure

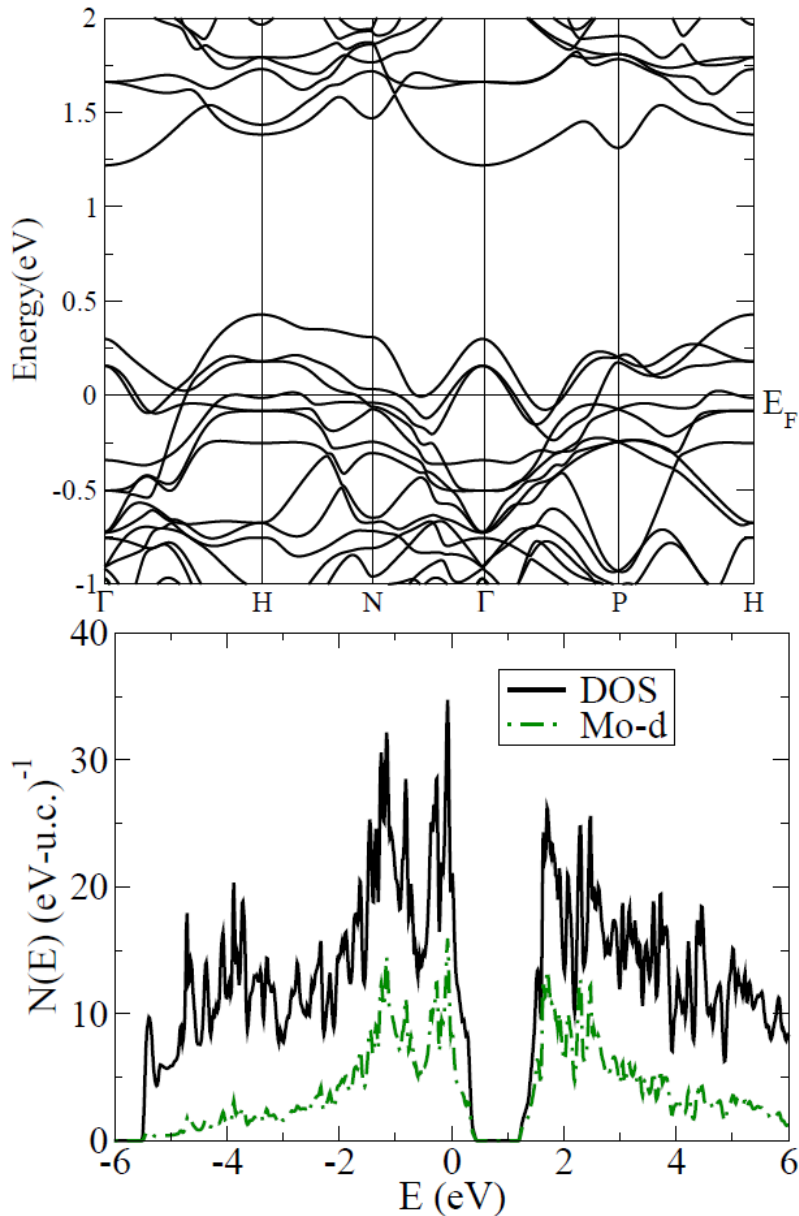

Stoichiometric Mo_3Sb_7 is a metal due to electron deficiency. Band edge is three electrons per formula unit higher.

Two strategies have been followed:

(1) Alloying Sb with Te.

(2) Alloying Mo with Ru, Fe, Ni or Mn

Issue in both cases is solubility limit.

We did virtual crystal and supercell calculations in order to address the doping dependence, as well as phonon calculations.

Supercell Electronic Structures – $\text{Mo}_5\text{MSb}_{14}$

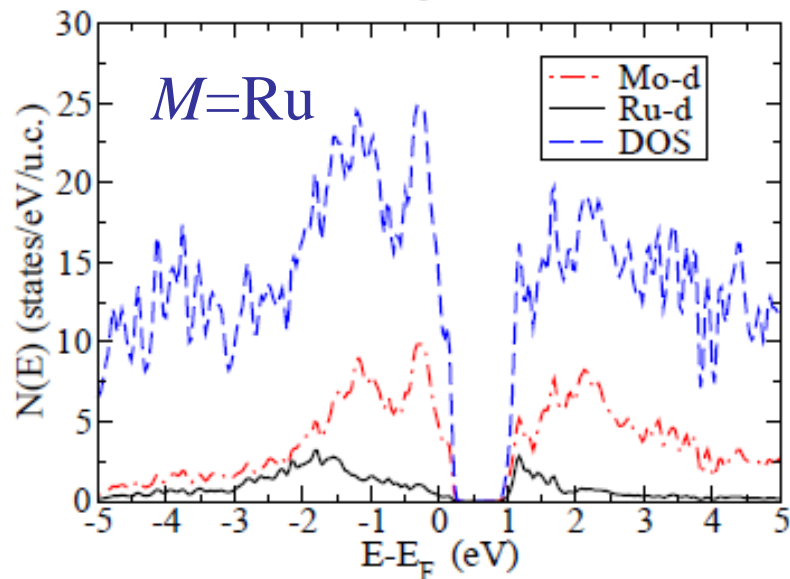
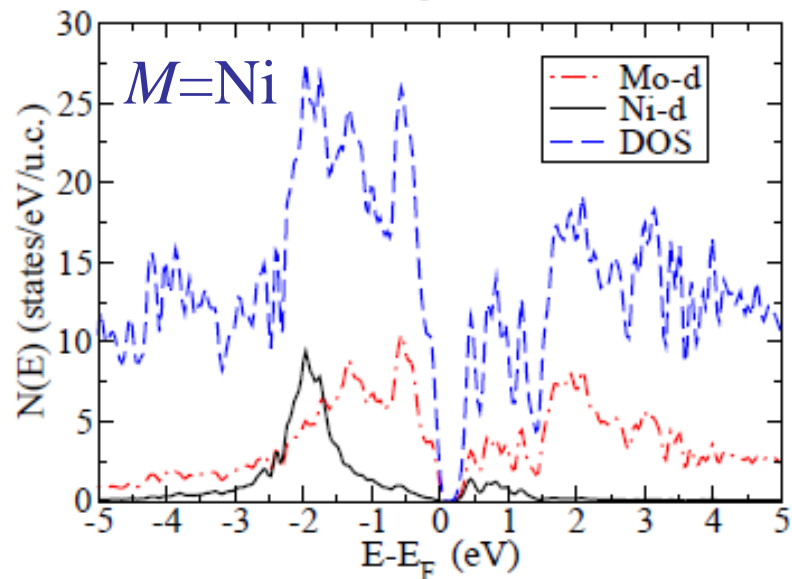
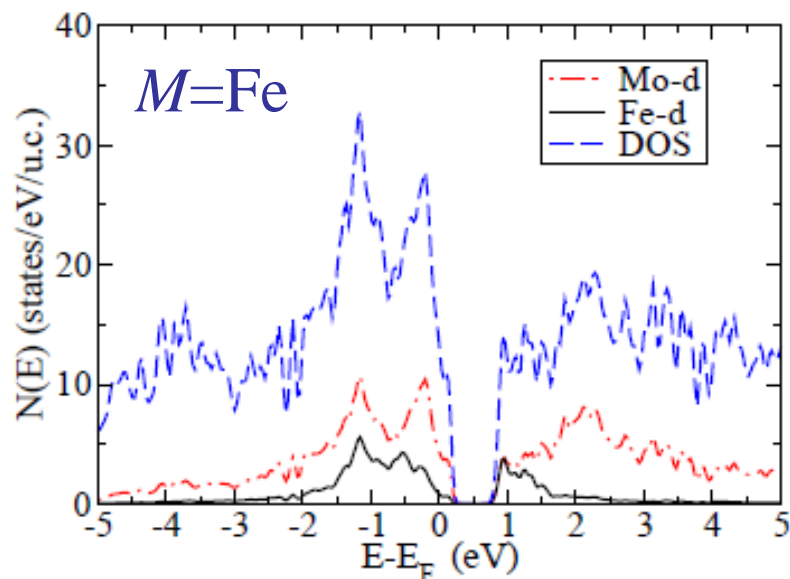
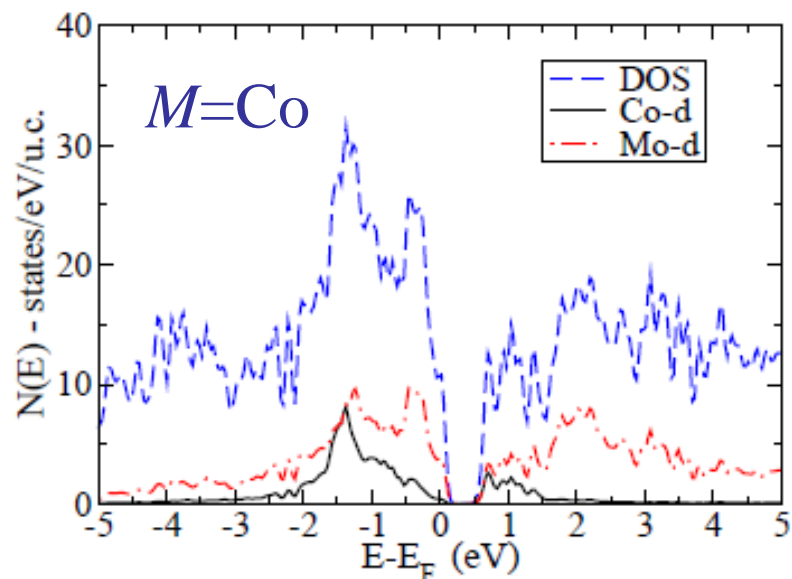

Fe and Ru show a DOS that is more coherent with Mo than do Ni or Co.

Supercell Electronic Structures – $\text{Mo}_5\text{MSb}_{14}$

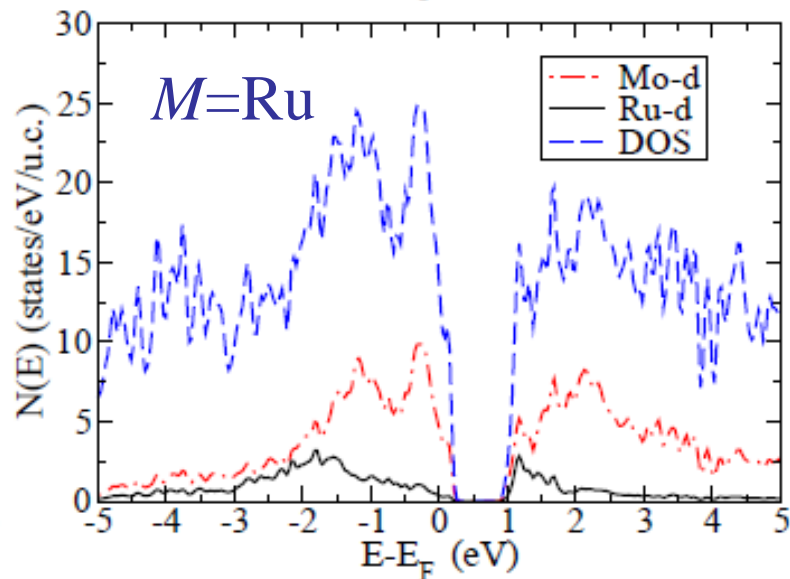
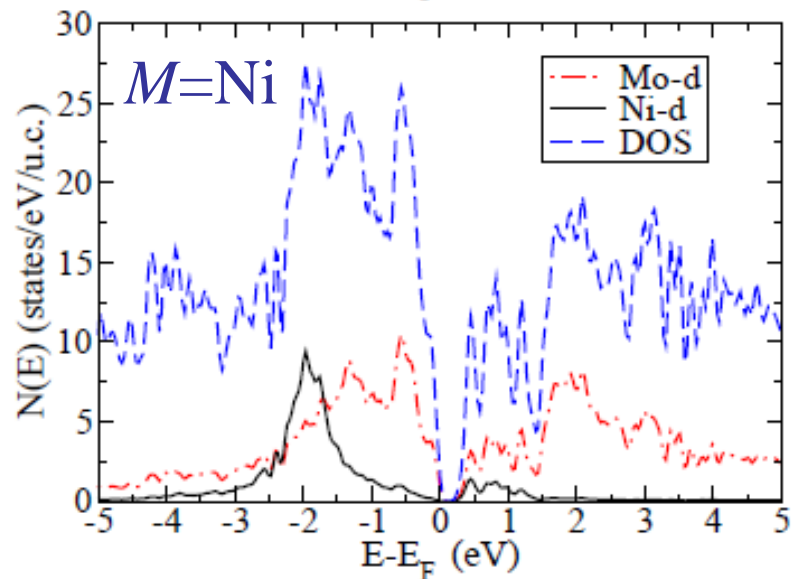
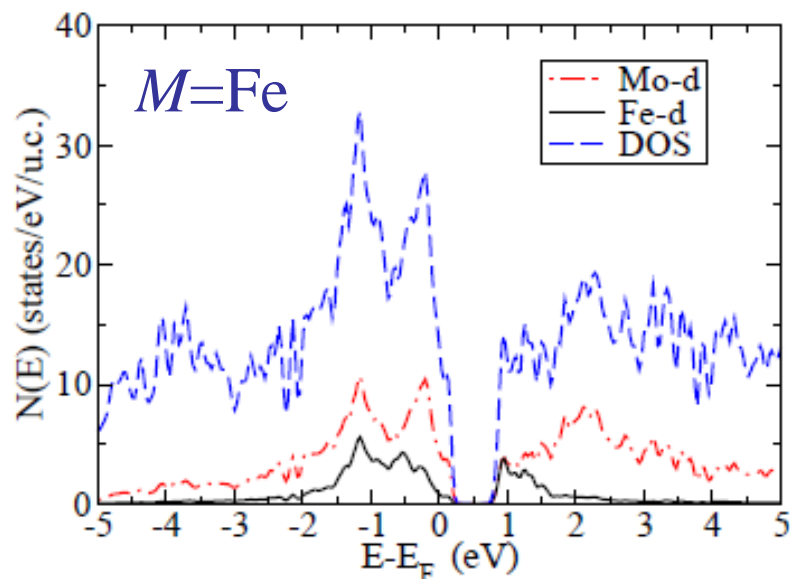
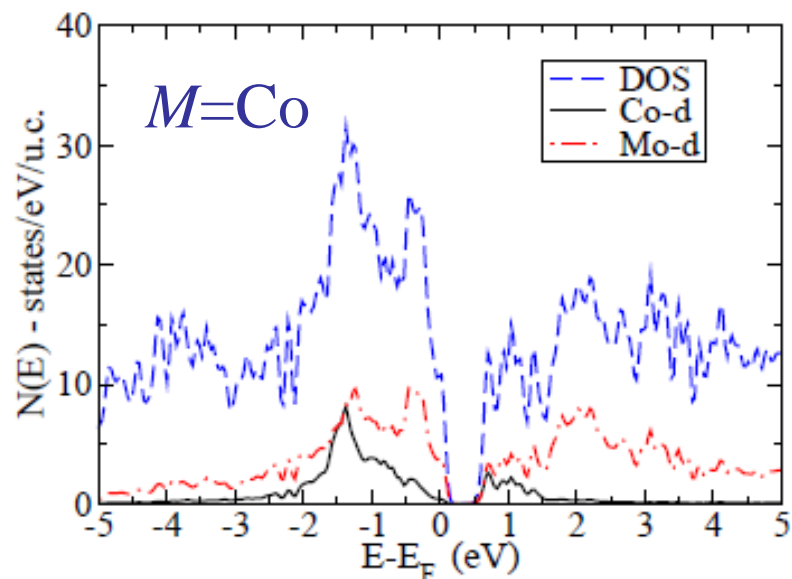

Fe and Ru show a DOS that is more coherent with Mo than do Ni or Co.

Vibrational Properties

Pure compound – acoustic type modes extend to $\sim 100 \text{ cm}^{-1}$ – these are the phonons that we need to scatter to lower lattice thermal conductivity. Fe, Co and Ni modes are at high frequency, though there is some mixing – probably a minor effect.

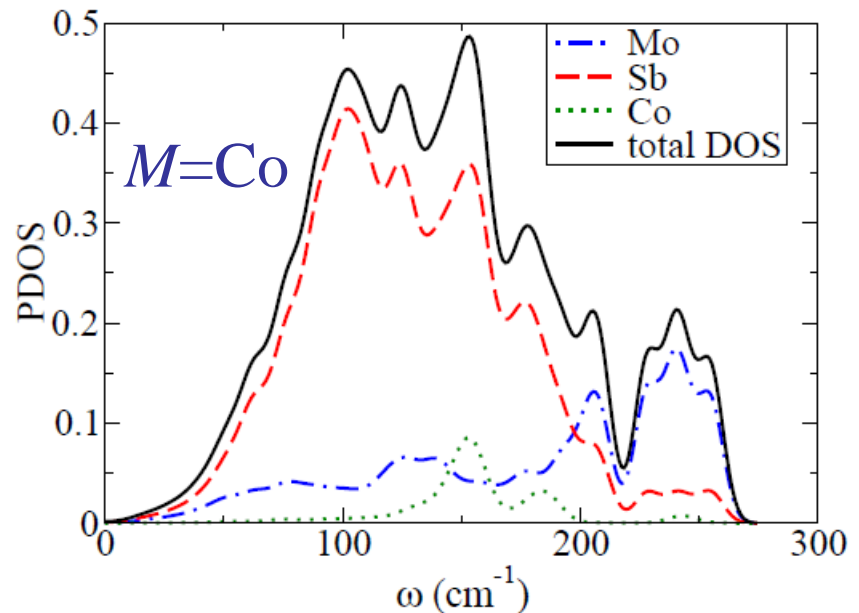
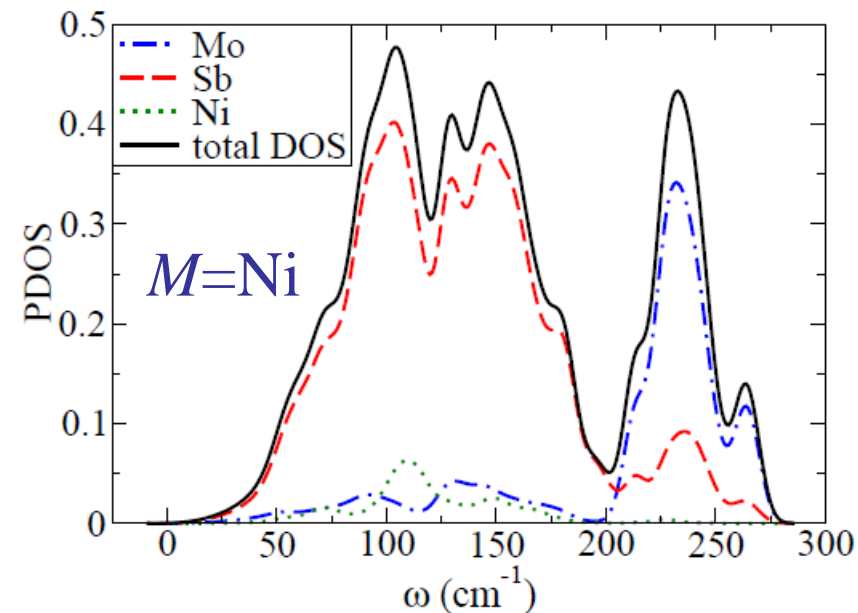
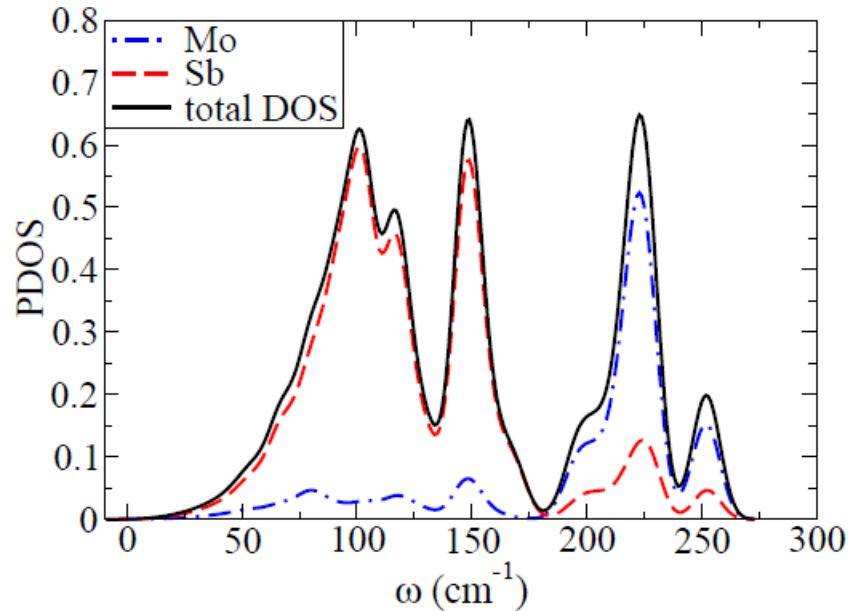

Transport: p-type Thermopower

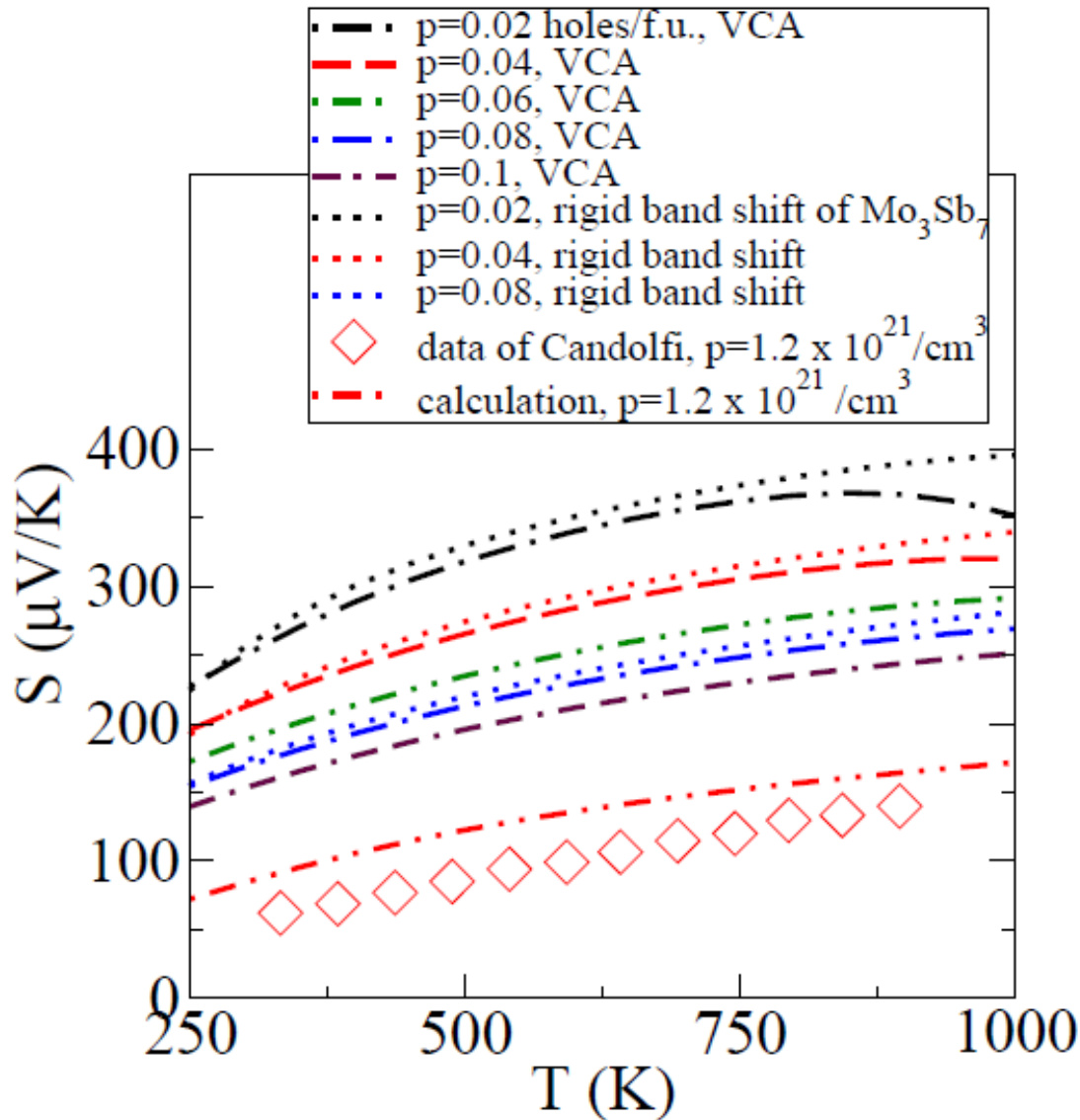

- Calculated $S(T,p)$ in relation to experiment implies that lower carrier concentrations will yield higher ZT – neither Te nor metal doped material are at their optimum carrier concentrations.
- Issue is solubility limit of metal on the Mo site.
- The structure of the densities of states suggest that co-doping with Fe and Co or Ni may be effective.

n-type ZnO

- Material that has been proposed as a high temperature n-type oxide thermoelectric.
- We did analysis of transport, similar to what was done on PbSe.
- Find that performance cannot be high unless something new is done to lower lattice thermal conductivity.

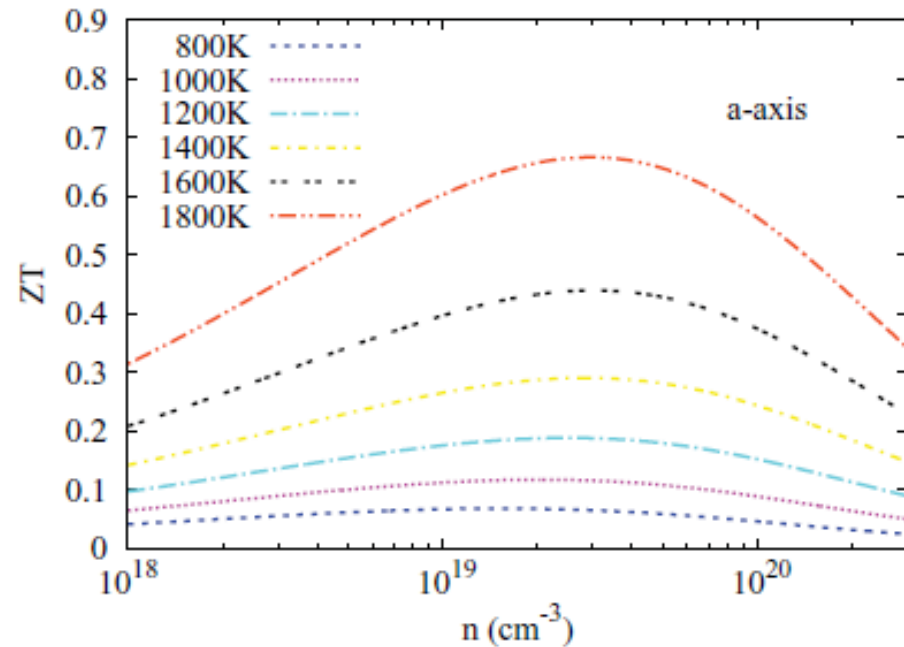
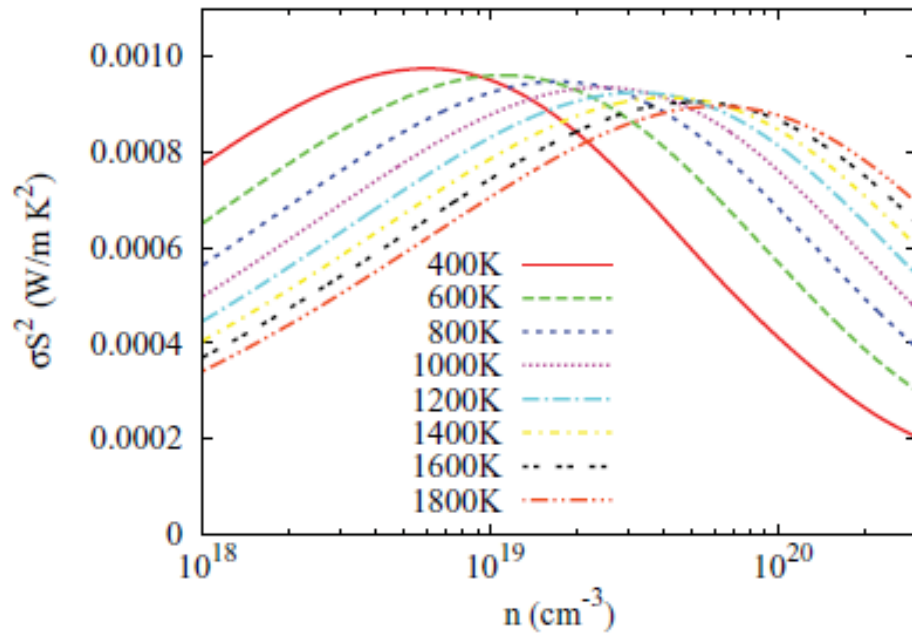

Thermal Conductivity: n-type ZnO

- Reported samples in literature are essentially optimized (bad news since $ZT \sim 0.5$).
- But there is hope:

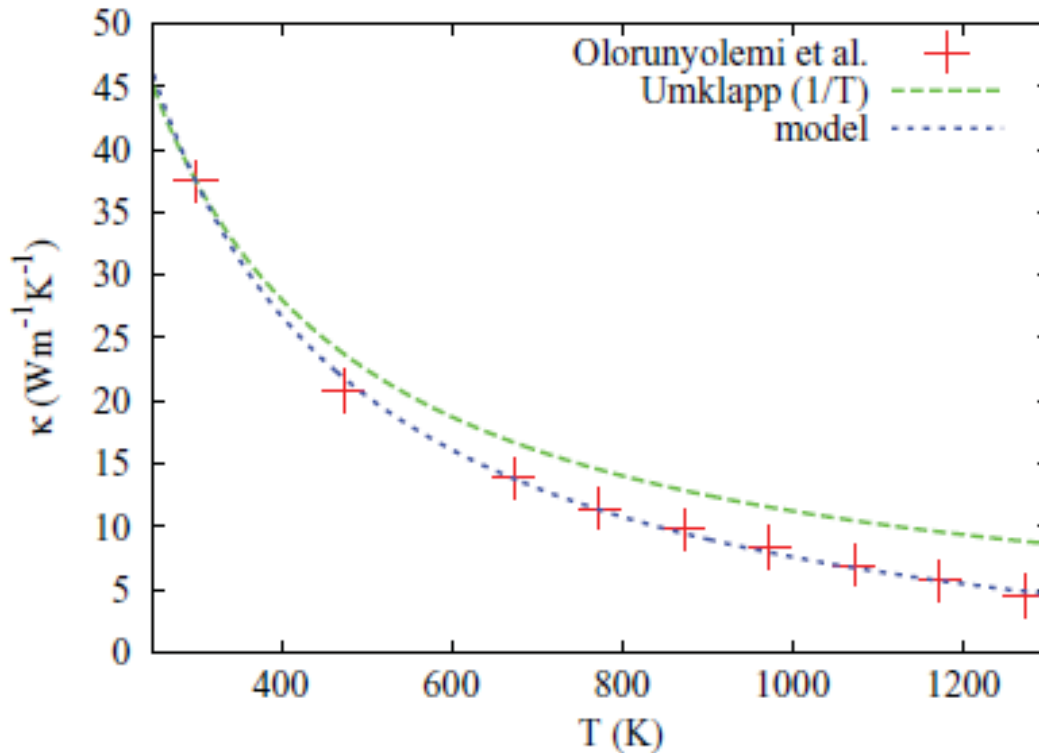

- Thermal conductivity in ceramic ZnO falls faster than $1/T$, and this appears related to nanostructure.
- Perhaps there is room for using nanostructure to get higher ZT .

And now for something completely different

I. Terasaki (1997): Na_xCoO_2 – an excellent thermoelectric!

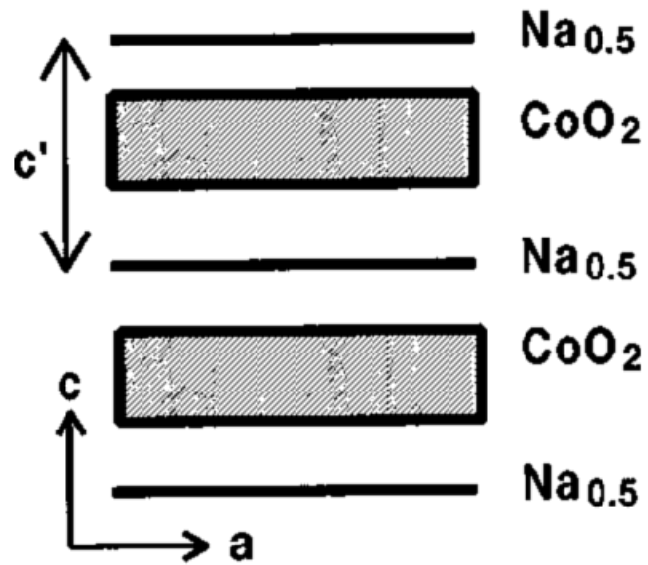

(a)

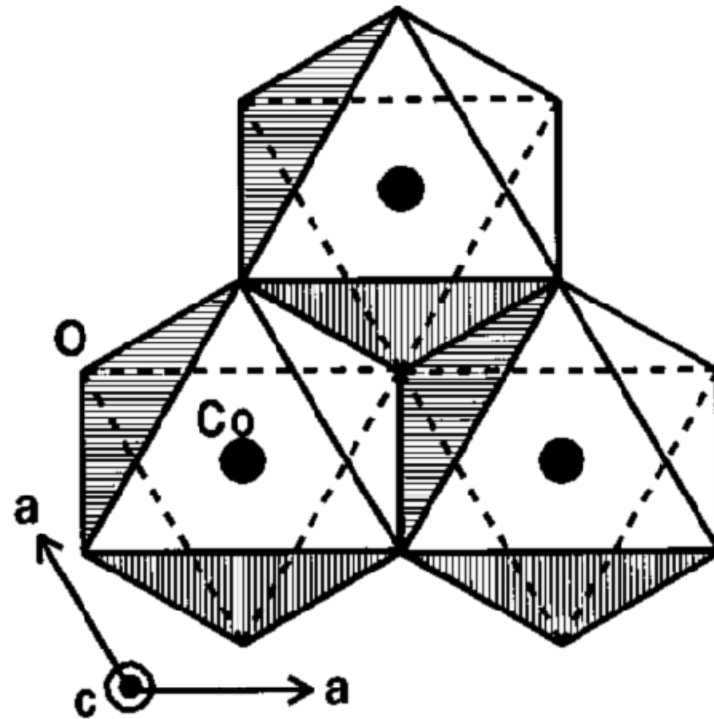

(b)

Importance of the 1997 Discovery (Terasaki, Sasago and Uchinokura)

Paradigm Change:

- High ZT Oxide Thermoelectric
 - Oxide semiconductors should have strong ionic scattering, and low carrier mobility.
- “Correlated” Thermoelectric
 - Strongly correlated materials can have high S , but they have low conductivity due to scattering.
- Metallic Thermoelectric
 - High carrier density metals have low S .

LDA Band Structure

LDA: Virtual Crystal

Narrow t_{2g} manifold with $1-x$ holes per Co.

U/W is large in the usual sense.

E_F is small.

Two sheets of Fermi surface.

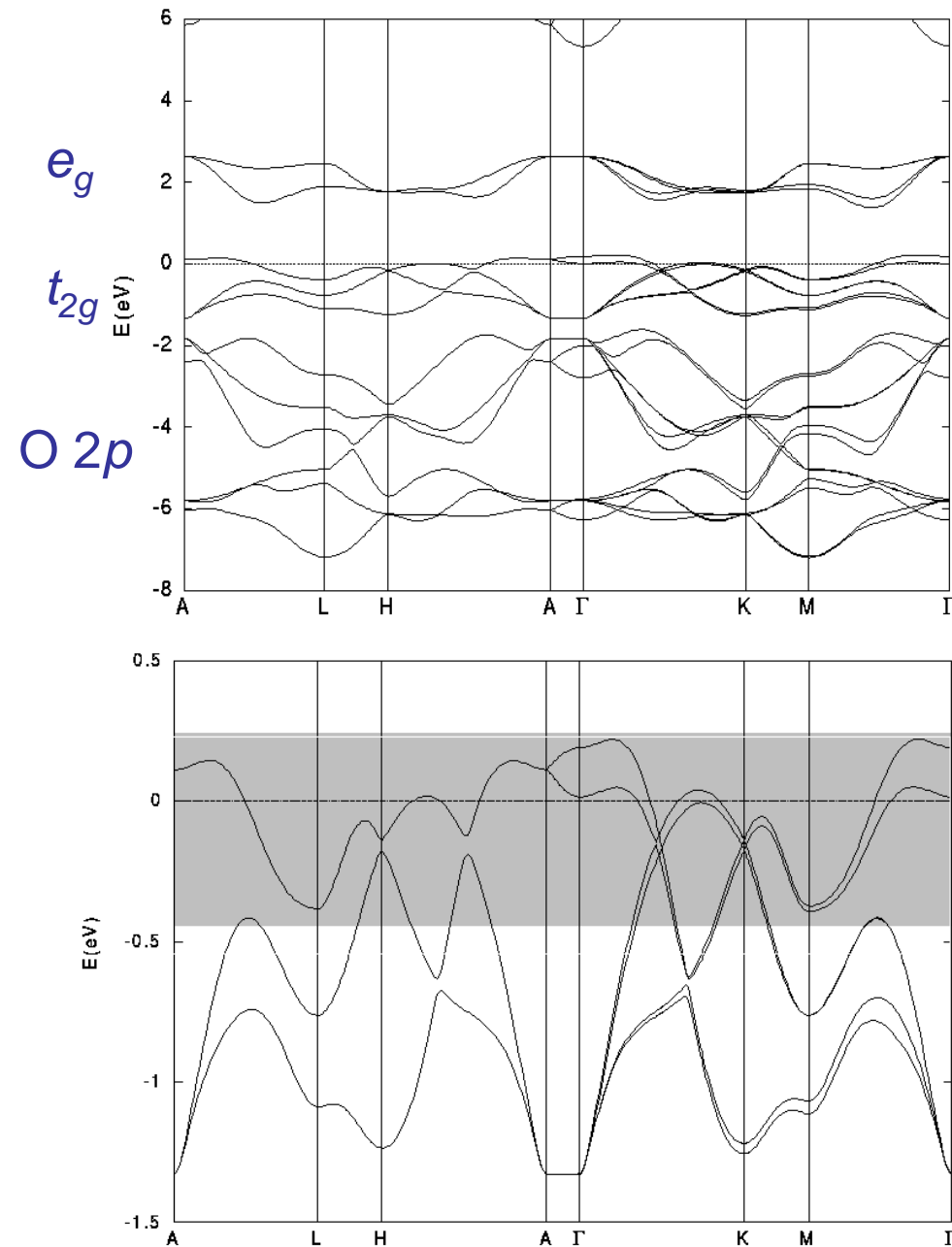

LDA Band Structure

Very narrow d -bands (both e_g and t_{2g}):

- Reason is topological (layered structure with edge shared octahedra):
 - Co – Co distance of ~ 2.84 Ang. is large enough to reduce direct hopping.
 - Bond angle near 90° (98°) reduces Co – O – Co hopping (neighboring Co hybridize with orthogonal p orbitals on shared O in both e_g - $p\sigma$ and t_{2g} - $p\pi$ channels.
- ***Narrow band width does not imply small Co-O hybridization (screening, renormalization of Hubbard U and charge fluctuations)***

Boltzmann Transport for Na_xCoO_2

Constant scattering time approximation (τ cancels), No adjustable parameters or experimental input other than crystal structure.

In-plane (out of plane is opposite sign).

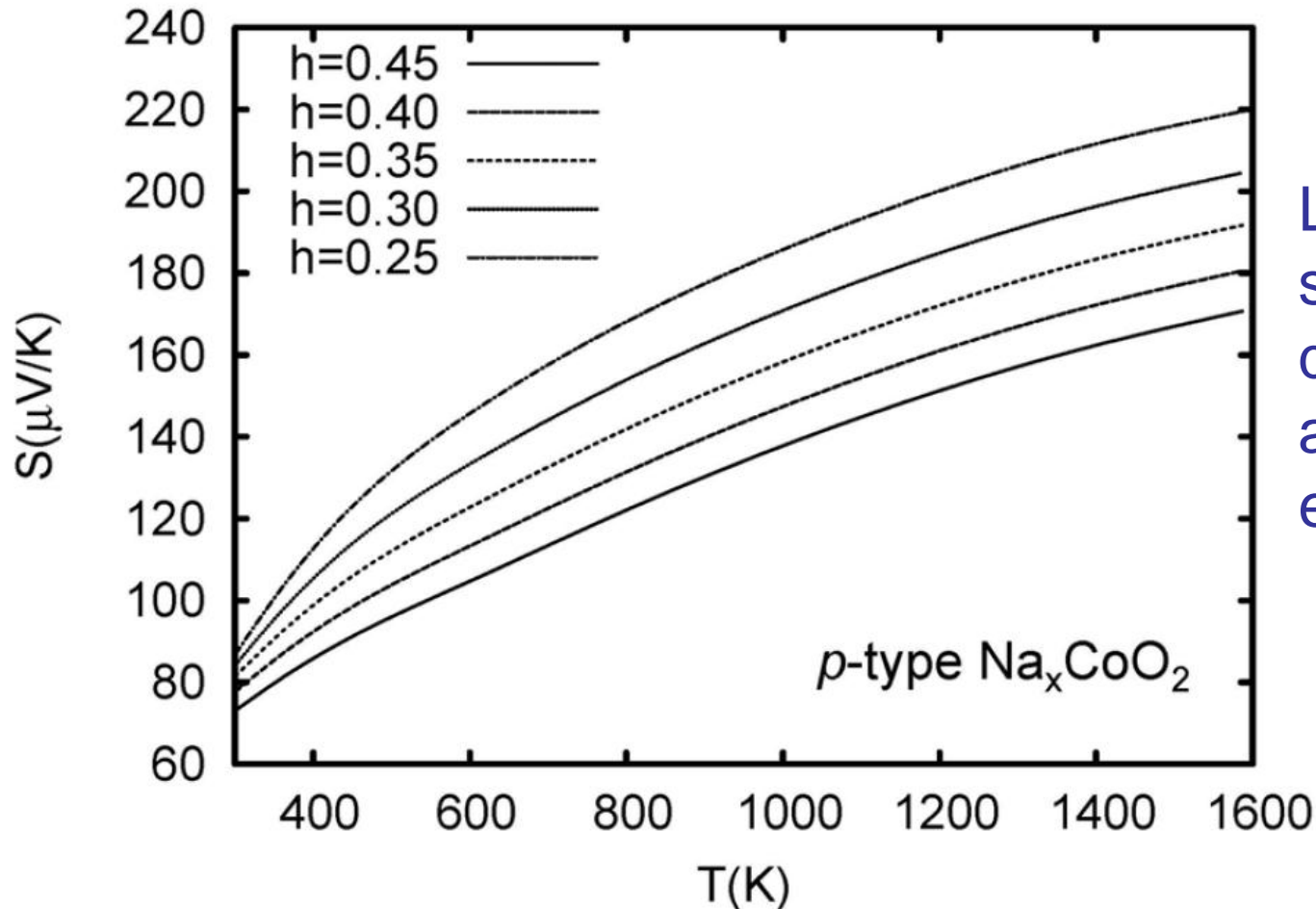

LDA band structure \rightarrow quantitative (10%) agreement with experiment.

A Key Point

Normally thermoelectrics have conducting frameworks with elements of similar electronegativity and other chemical aspects that favor high mobility.

However, very heavy but still metallic bands buy a lot → go to very high carrier concentrations and still get high $S(T)$. In this regime point defect scattering is not so important.

Electronic Transport: 2D vs. 3D

Low T (refrigeration):

$$2D: S/T \propto m/n$$

$$3D: S/T \propto m/n^{2/3}$$

So 2D is better at low T or when the lattice thermal conductivity is negligible compared with the electronic thermal conductivity (but note don't normally optimize in that range).

High T (power generation):

Both 2D and 3D have $\sigma/\tau \propto \Omega_p^2 \propto n/m$, but in 2D $N(E_F)$ is higher

→ more phase space for e-p scattering.

Advantage of low dimensionality is lost for high temperature where electron phonon scattering rate is proportional to the available phase space [$\sim N(E_F)$].

Delafossite Structure Cobaltates

- CuCoO_2 and AgCoO_2 are known insulators, PdCoO_2 is metal
- Recent work by Shibasaki et al. on Rh delafossite shows high S .

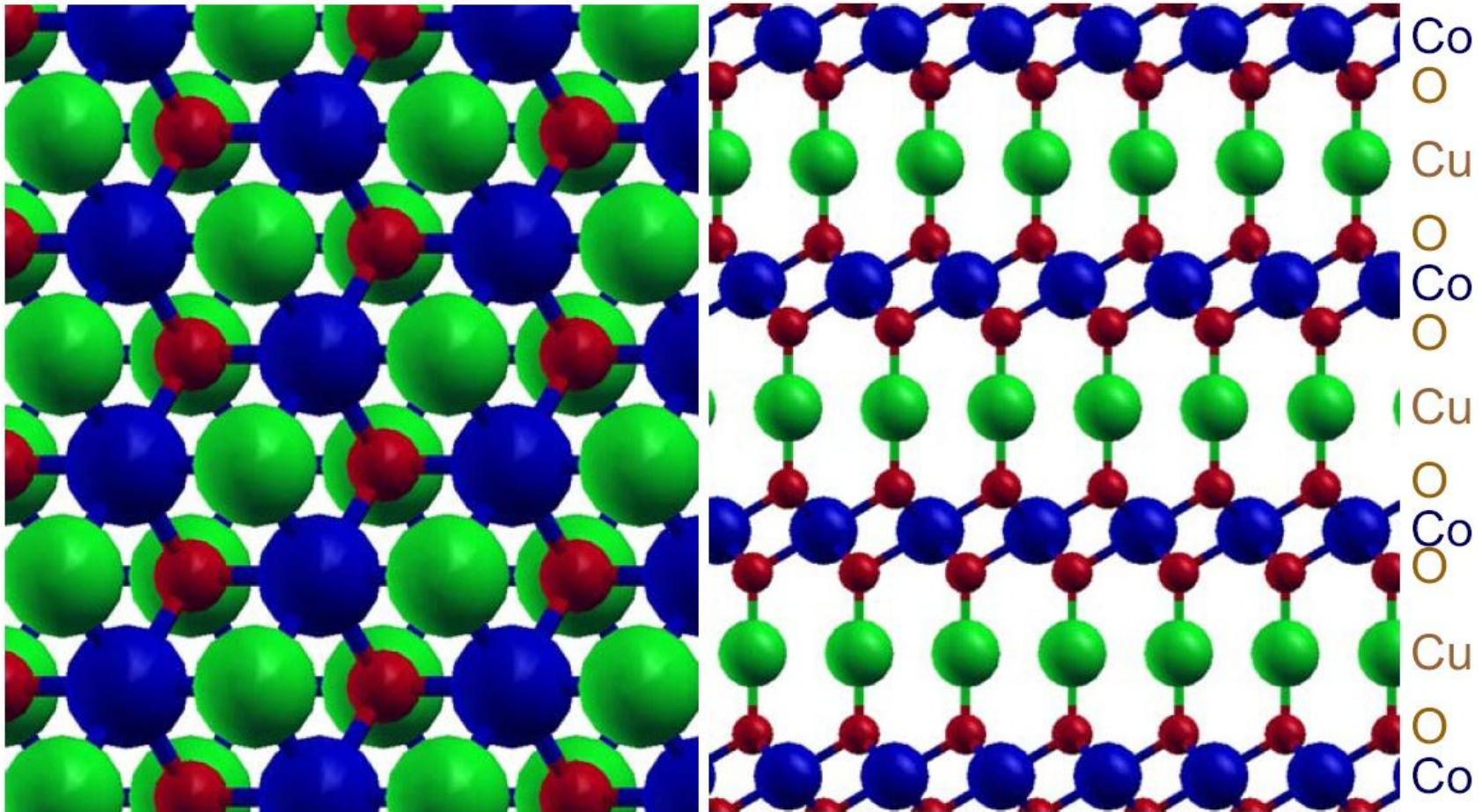

CuCoO₂ Electronic Structure

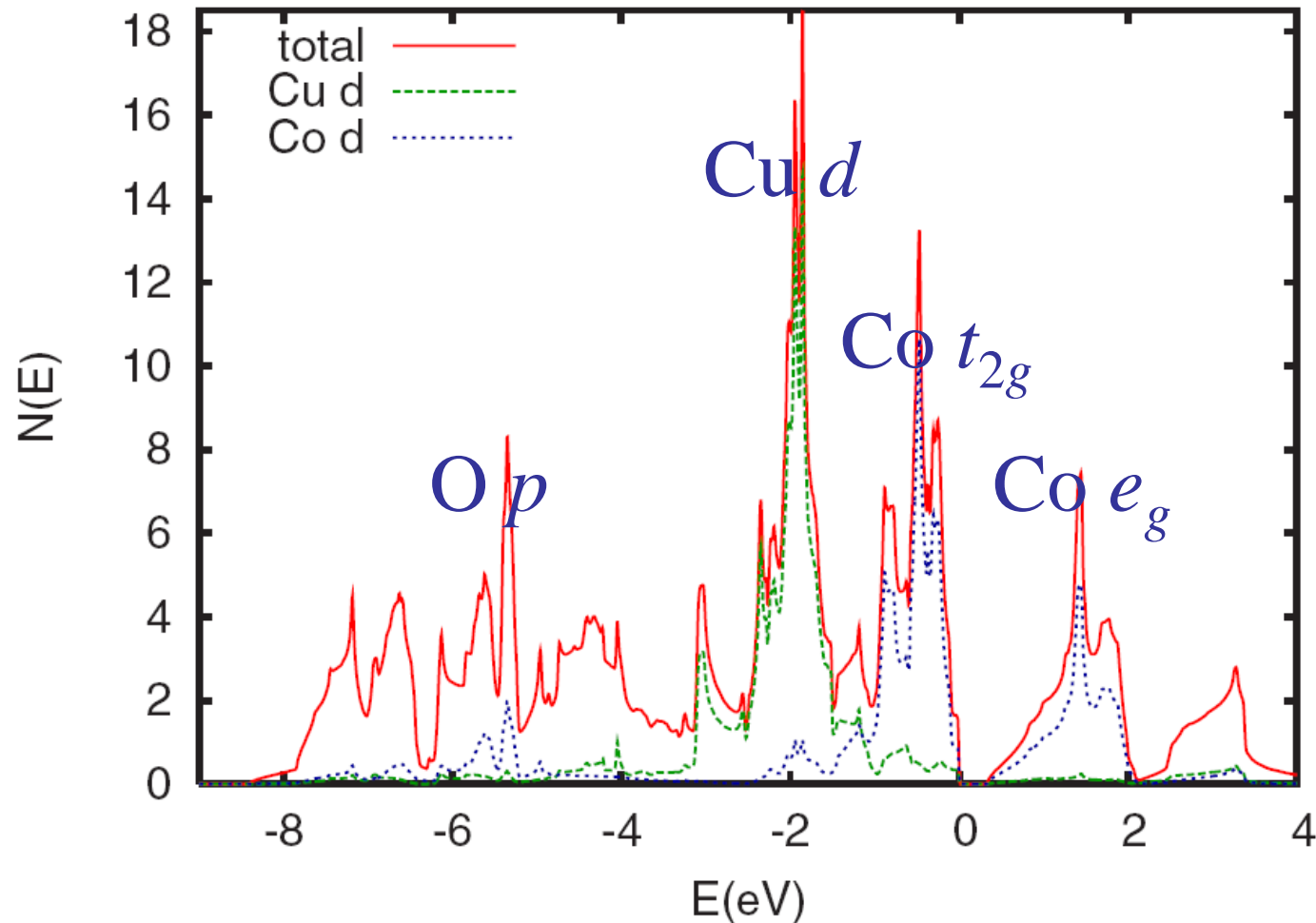

Interaction with higher lying bands produces a tail on the e_g manifold
→ smaller gap (0.4 eV)
→ could be made n -type?

Band structure (not shown) is much more 3D in character due to interaction with other bands.

CuCoO₂ Thermopower

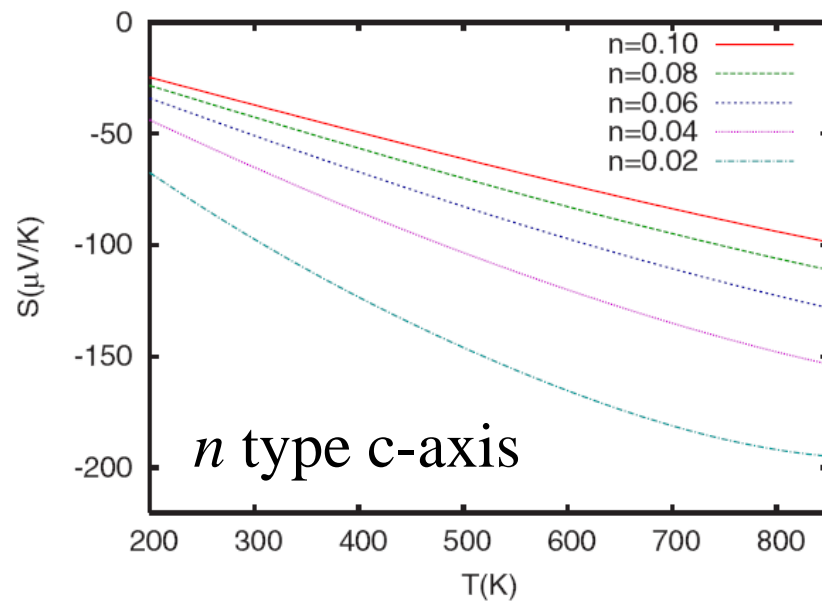
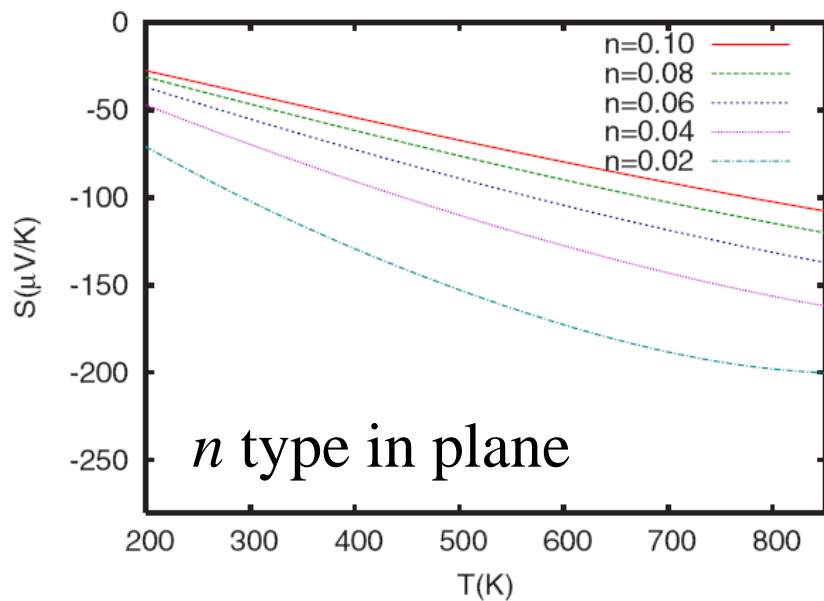
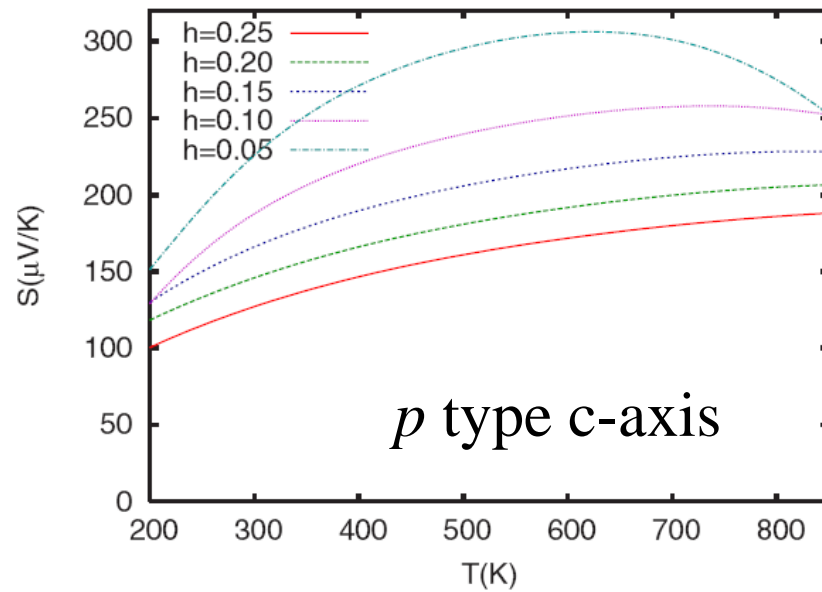
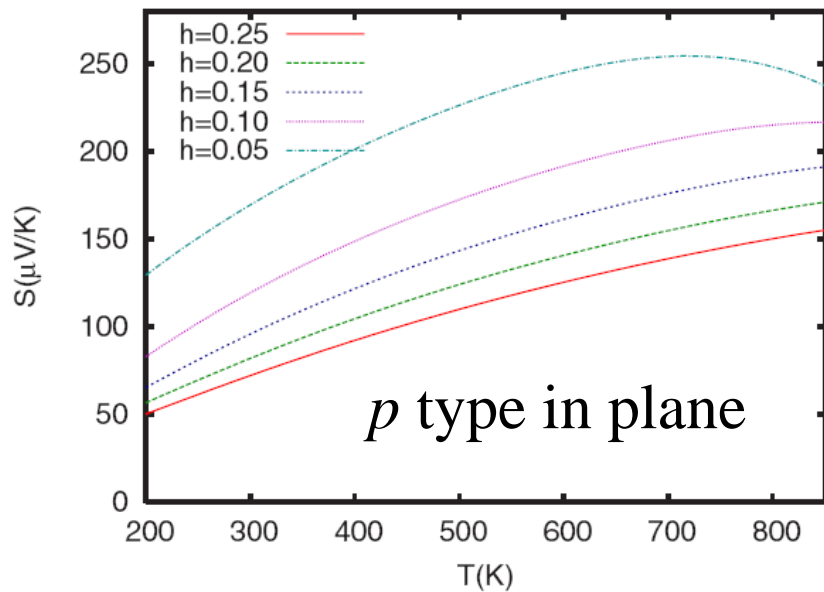

Thermoelectric power of delafossite-derived compounds, $RCuO_{2+\delta}$ ($R = Y, La, Pr, Nd, Sm, \text{ and } Eu$)

Kazuyuki Isawa, Yuji Yaegashi, Seiya Ogota, Mitsugu Nagano, and Shiroshi Sudo
Research and Development Center, Tohoku Electric Power Co., Inc., 2-1 Nakayama 7-chome, Aoba-ku, Sendai 981, Japan

Kazuyoshi Yamada
Department of Physics, Tohoku University, Aramaki, Aoba-ku, Sendai 980-77, Japan

Hisao Yamauchi
Materials and Structures Laboratory, Tokyo Institute of Technology, Nagatsuta, Midori-ku, Yokohama 226, Japan

(Received 3 November 1997)

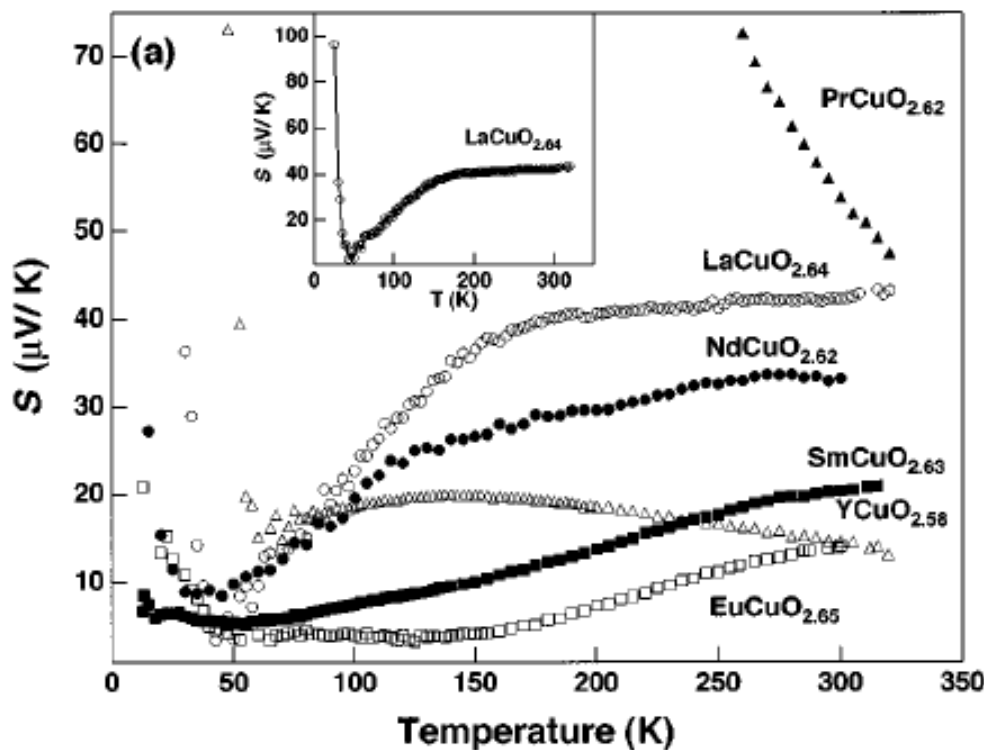

Found rather high values
of S for metals.

YCuO₂ Delafossite

- Known conductive oxide, though not characterized in single crystal form.
 - Of interest as a transparent conductor, and also in oxide electronics.
 - Successful use as a hydrogen photocathode was reported.
 - Can accommodate large amounts of excess O.
 - As made material is invariably *p*-type.
 - Related to another interesting family of conductive Cu oxides, e.g. YBa₂Cu₃O₇
- Implies that the material can be doped with mobile carriers.

YCuO₂ Band Structure

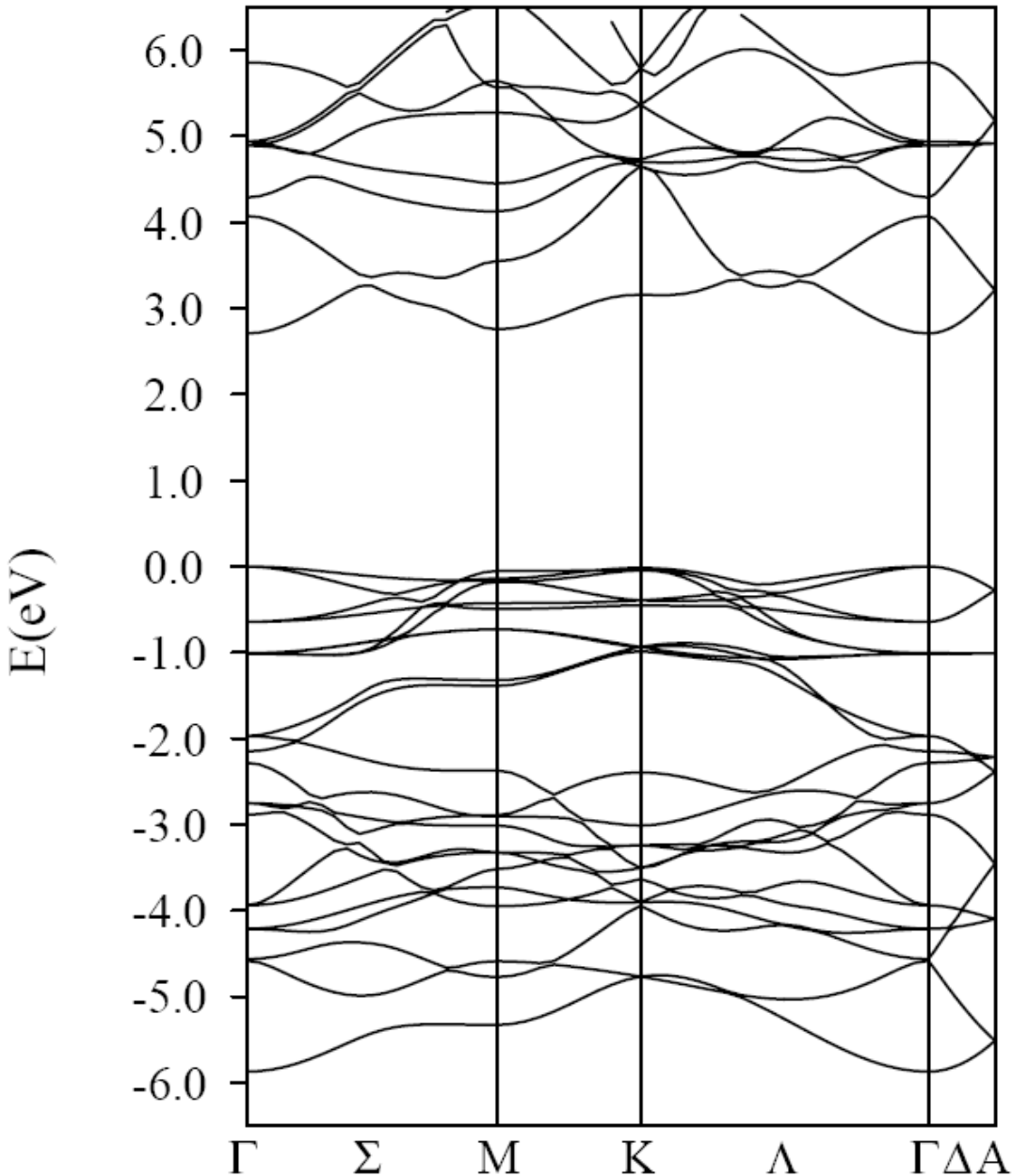

Cu/Y sp
Y d

Cu $3d$
O $2p$

p -type carriers
are in Cu d
bands

c.f. Mattheiss 1993

YCuO₂ Thermopower

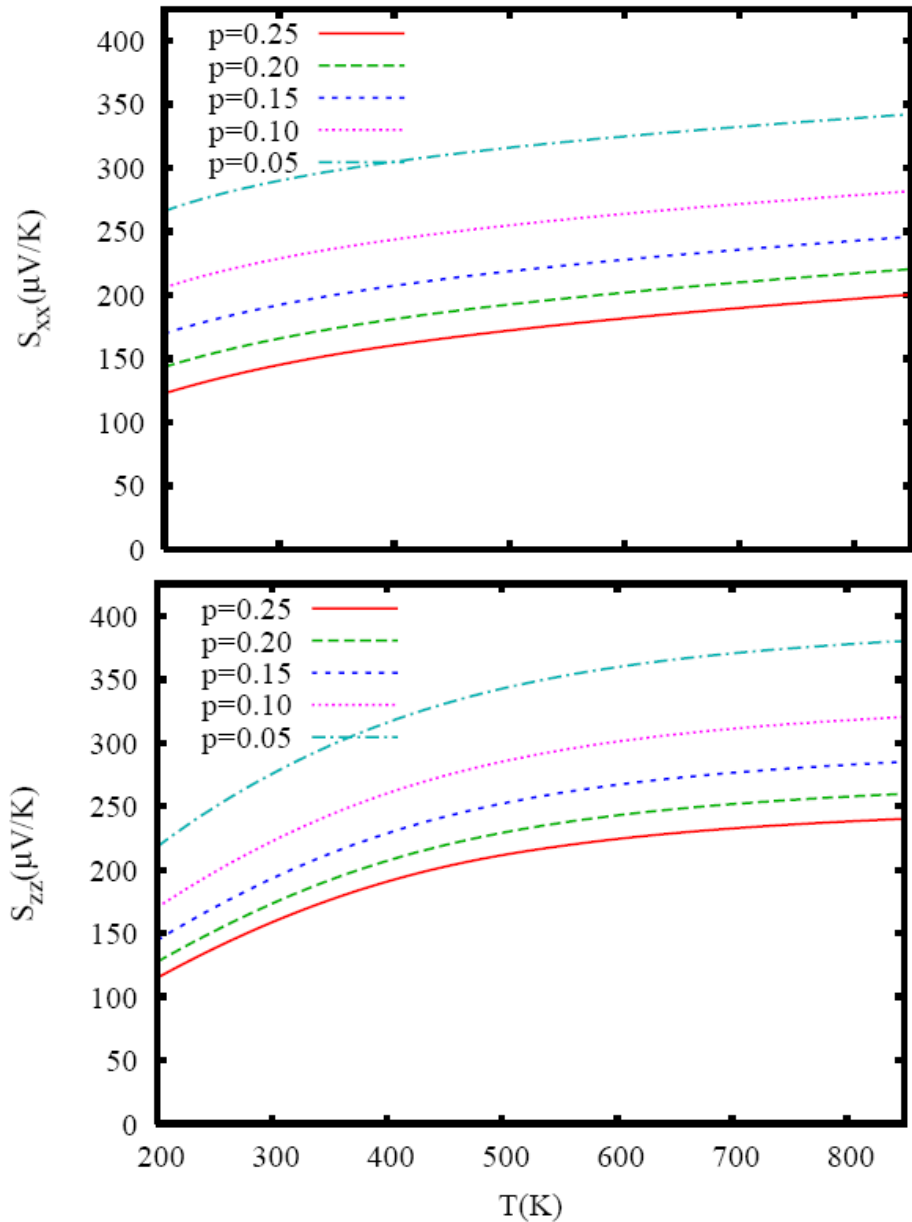

Very high thermopowers, exceeding that of Na_xCoO₂ for comparable doping levels.

Anisotropy of thermopower is modest, unlike Na_xCoO₂.

Reason is 3D bands vs. 2D bands.

Conductivity

Recall:

$$\sigma_x(T) = e^2 \int d\varepsilon N(\varepsilon) v_x^2(\varepsilon) \tau(\varepsilon, T) (-f'(\varepsilon))$$

Scattering time does not cancel, and in general depends strongly on doping, temperature, defect concentration etc.

However, can get some direct information from band structure:

(1) $\tau(\varepsilon, T)$ is isotropic:

$$\sigma_x(T) / \sigma_z(T) = \langle v_x^2 \rangle / \langle v_z^2 \rangle$$

i.e. conductivity anisotropy can be obtained directly with the approximation of isotropic scattering time.

Conductivity Anisotropy of YCuO_2

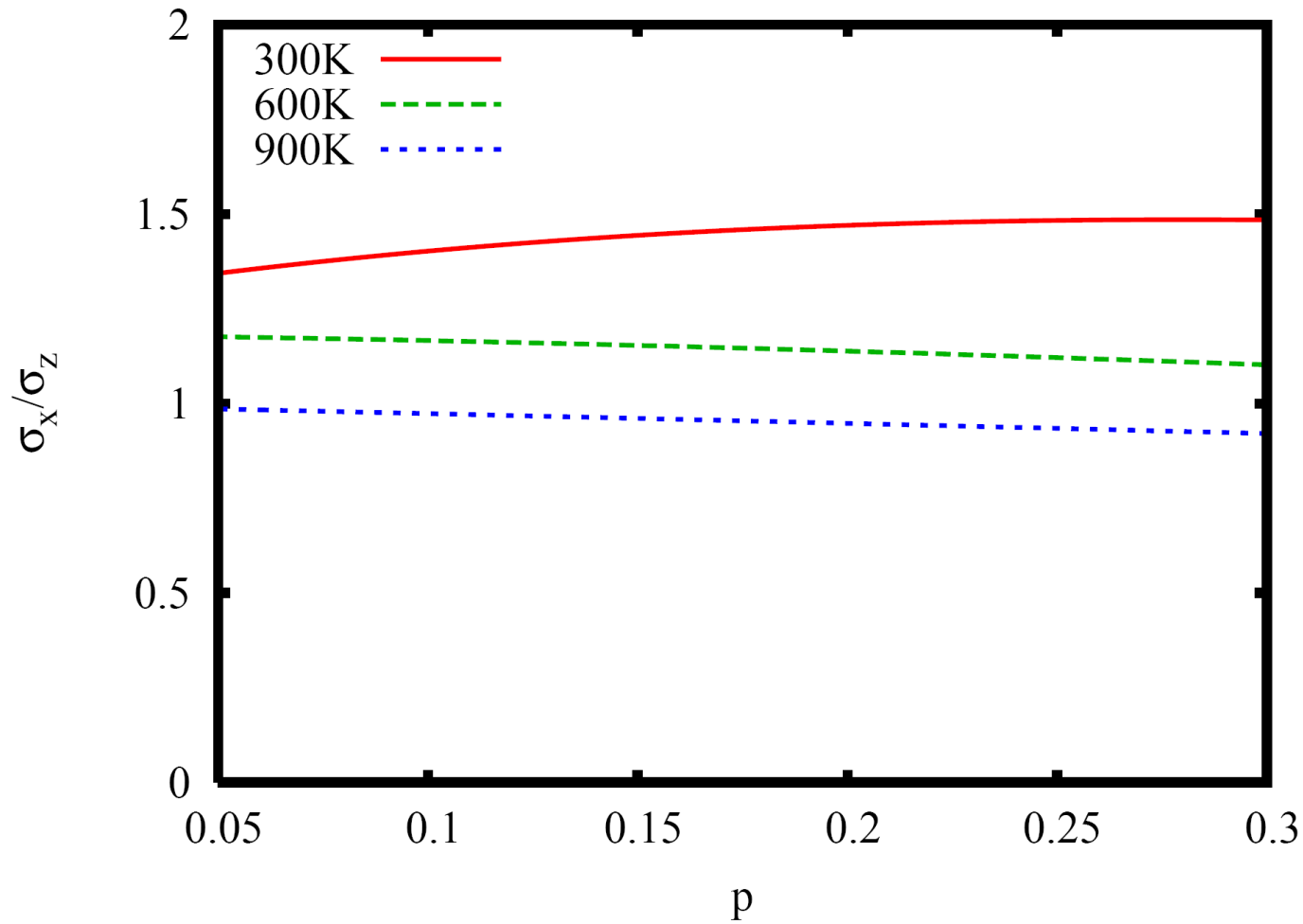

Note T dependence. Anisotropy is less than 1.5 and decreases as T increases.

Power Factor Anisotropy of YCuO₂

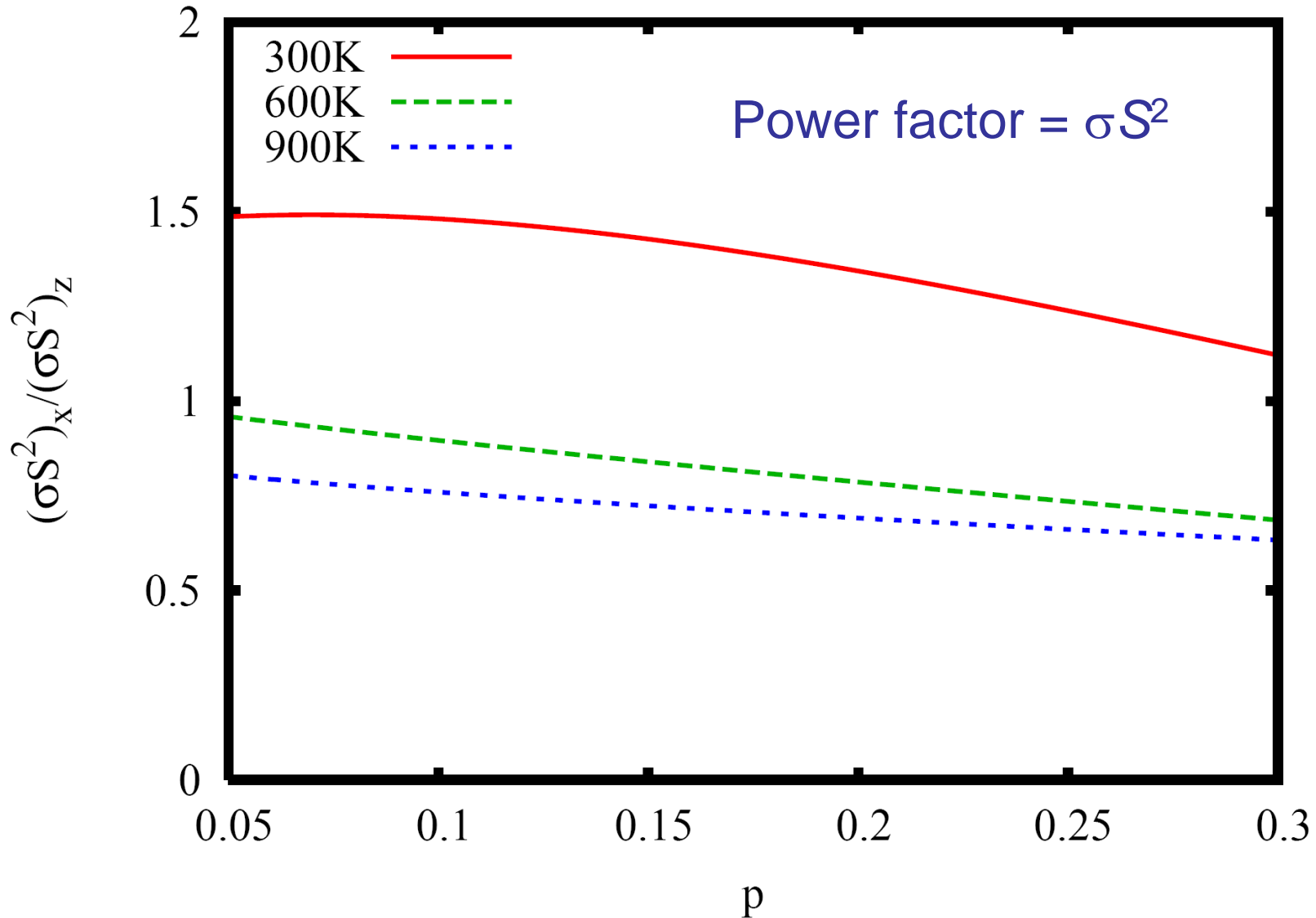

Dominated by anisotropy of S. Anisotropy is ~1.5 or smaller.

PdCoO₂ and PtCoO₂

$$s = \left(\frac{\pi^2 k_B^2 T}{3e\sigma} \right) \frac{\partial \sigma}{\partial E} \Big|_{E=E_F}$$

Thermopower is quite isotropic in semiconductors.

Need not be the case in metals, but then thermopower is small in all directions (no low energy scale).

Extremely good metals in plane, with high anisotropy of conductivity.

c.f. ReO₃ with $\rho(300\text{K})=10 \mu\Omega \text{ cm}$

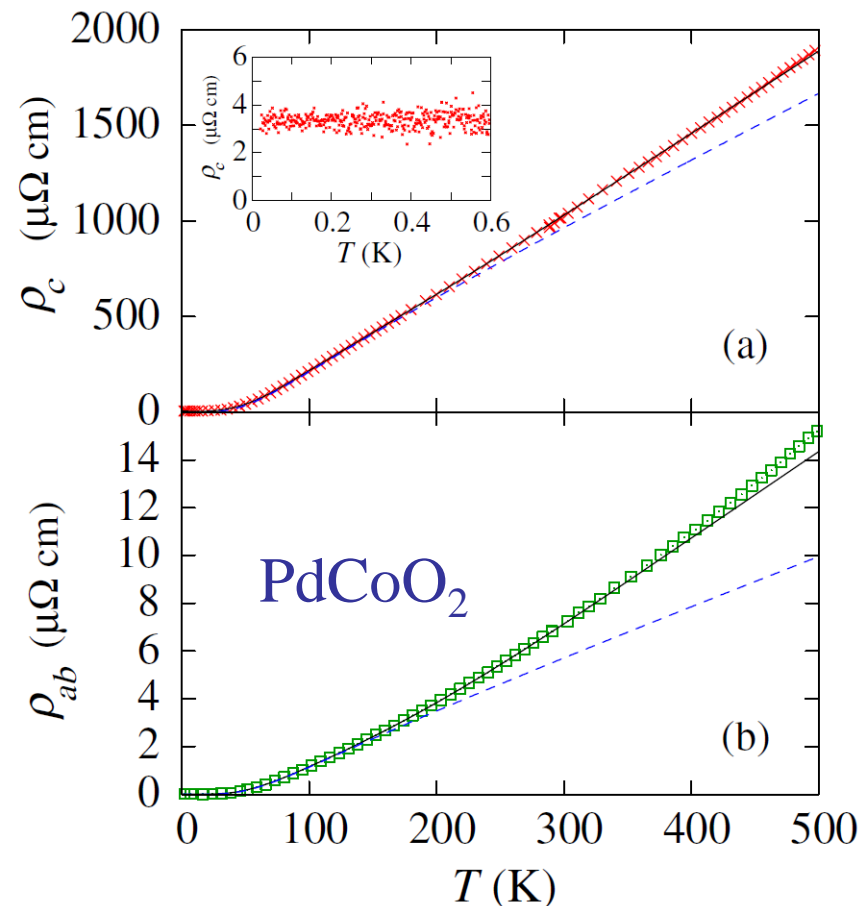

Thermopower of PdCoO₂ and PtCoO₂

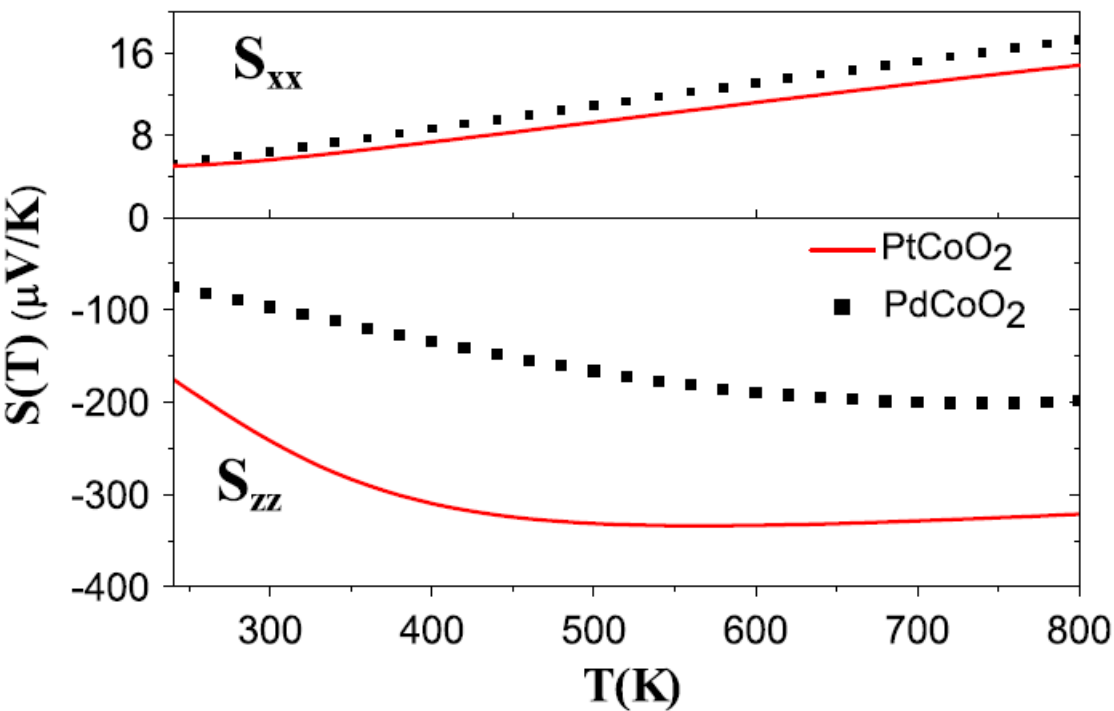

We found a huge anisotropy of S with high value in the c -axis direction.

Reason is a strong energy dependence of the anisotropy in the conductivity.

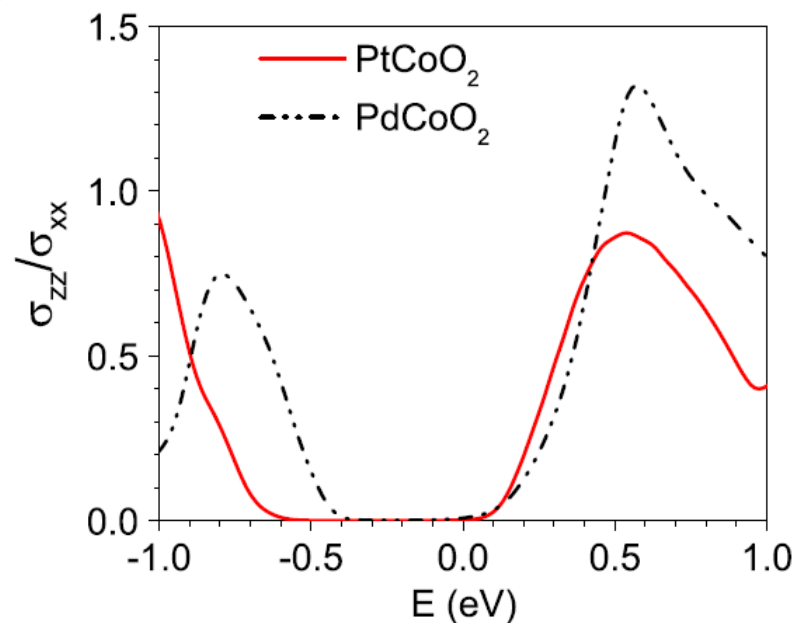
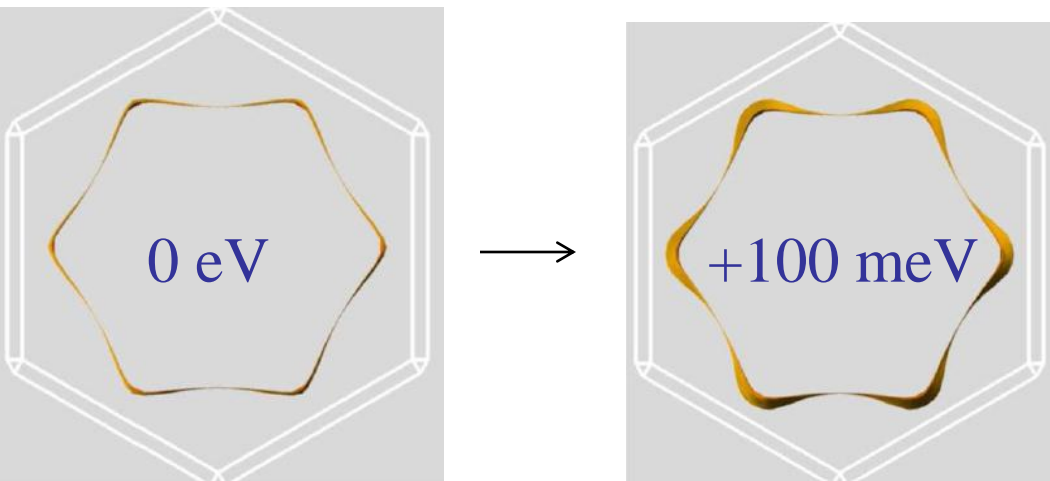

Summary: Pathways to High ZT

$$ZT = \sigma S^2 T / \kappa = r S^2 / L \quad r = \kappa_e / (\kappa_e + \kappa_l)$$

→ need high S and high r (low lattice thermal conductivity).

1. Thermopower:

- Narrow bandwidth oxides (Na_xCoO_2).
- Heavy and light bands (filled skutterudite, La_3Te_4).

2. Lattice thermal conductivity:

- Rattling ions (Phonon-Glass-Electron-Crystal).
- Nanostructuring (different phonon and electron MFP)
- Nearness to lattice instabilities.

3. Optimization:

- Designer materials (e.g. Zintl phases).